

Colorado/Canyon and Saturn Ion 2004

PLK2/Start Integration

These vehicles have two pass lock wires which function as keysense, 2nd ignition and also function as pass-lock 2 wires in addition to being able to crank the engine in conjunction with the accessory wire losing voltage. The Ion can also use Doc 1610 using a 555L.

Test for the resistor value as follows:

1. Start the car with key.
2. Cut WHITE/BLUE or WHITE wire and measure the resistance (ohms) of the key side of the cut wire against the WHITE/YELLOW or WHITE/BLACK reference wire in the CRANK position (the vehicle has built in anti-grind).

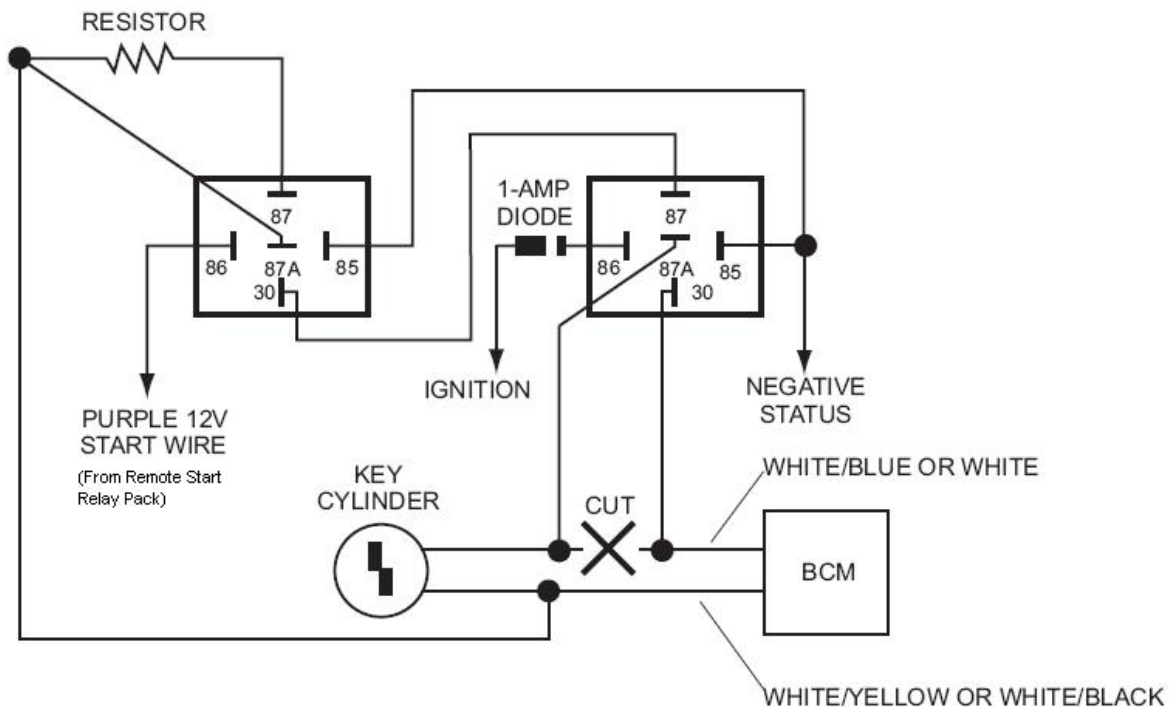

IMPORTANT! This wiring information is being provided free of charge on an "as is" basis, without any representation or warranty. It is the dealer's responsibility to verify any circuit before interfacing with it using a digital multi-meter. Directed Electronics Inc. assumes no responsibility with regards to the accuracy or currency of this information. Proper installation in every case remains the responsibility of the installer.