



415

INSTALLATION GUIDE

Table of Contents

Installation Points to Remember	2	Plug-In Harnesses	16
Tools Required	3	Super Bright LED	16
Deciding on Component Location	3	Valet/Program Switch	16
Siren	3	On-Board Dual Stage Shock Sensor	16
Control Module	4	Internal Programming Jumper	17
Valet®/Program Switch	4	Light Flash Jumper	17
Status LED	4	System Features Learn Routine	18
Starter Kill Relay	5	System Feature Menu	19
Connecting Your Wires	5	To Access Another Feature	19
Constant 12V	5	To exit the learn routine	19
Switched Ignition	5	Feature Descriptions	20
Parking Light Wire	6	Table of Zones	21
Door Switch Circuit	6	Rapid Resume Logic	22
Starter Wire	7	Troubleshooting	22
Making Your Connections	7		
Primary Harness Diagram	8		
Wire Connection Guide	9		
Primary Harness	9		
5-Pin Auxiliary Plug	12		
Door Lock Learn Routine	16		

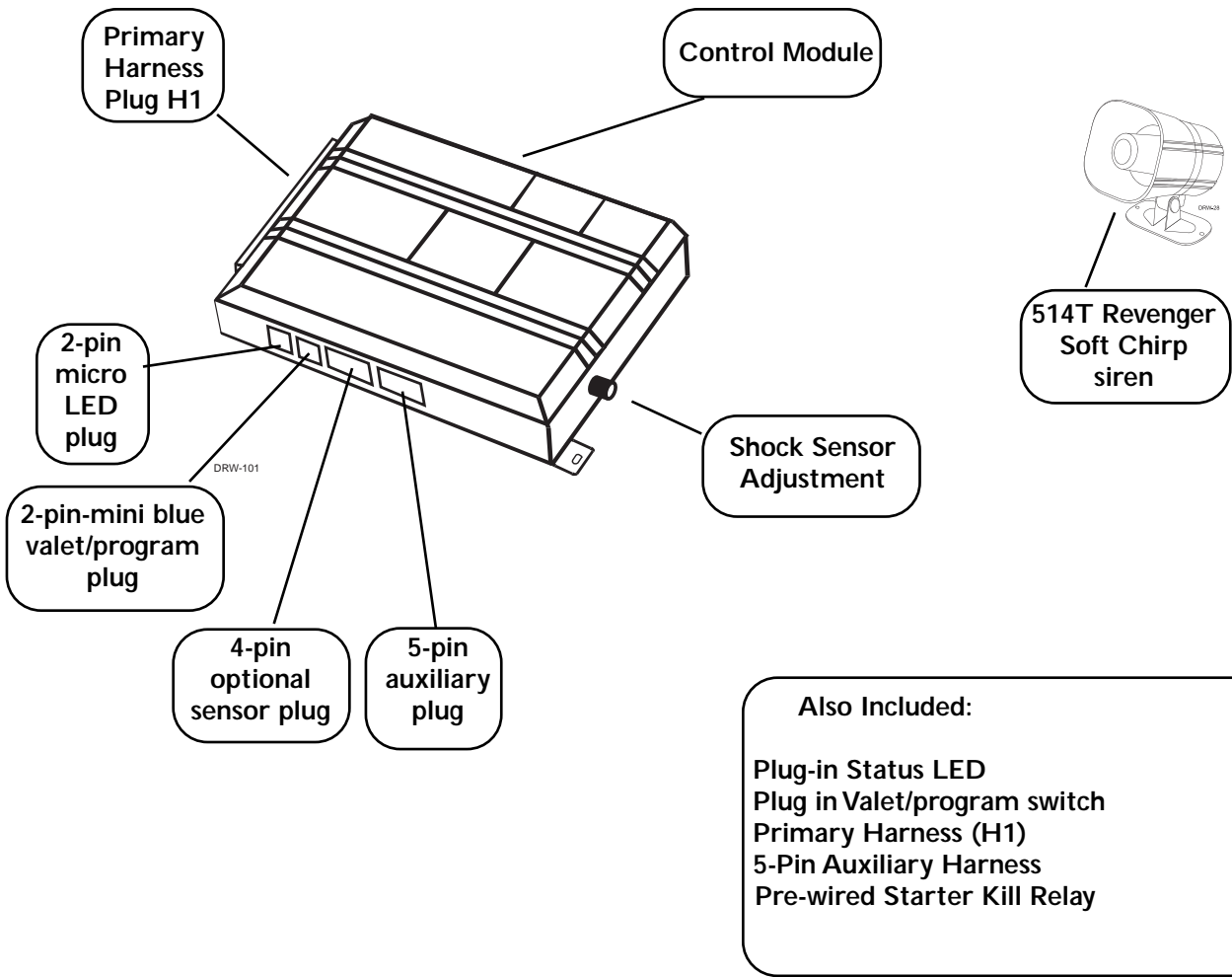

INSTALLATION POINTS TO REMEMBER

Before beginning the installation:

- Check with the customer on Status LED location.
- Use seat and fender covers to protect the vehicle.
- Remove the domelight fuse. This prevents accidentally draining the battery.
- Roll down a window to avoid being locked out of the car.
- Do not disconnect the battery if the vehicle has an anti-theft coded radio. If equipped with an air bag, avoid disconnecting the battery if possible.
- Remove necessary under-dash trim panels to provide access for mounting the system's components.

IMPORTANT! Please read this entire installation guide before beginning the installation. The installation of this security system requires interfacing with many of the vehicle's systems. Many new vehicles use low-voltage or multiplexed systems which can be damaged by low resistance testing devices, such as test lights or logic probes. Test all circuits with a high-quality digital multi-meter before making the connections.

IMPORTANT! Many airbag systems will display a diagnostic code through their warning light after they lose power. Disconnecting the battery requires this code to be erased, which can require a trip to the dealer.

After the install:

- Test all functions. The "Using Your System" section of the Owner's Guide is very helpful when testing.
- When testing, don't forget that this system is equipped with Nuisance Prevention® Circuitry. NPC™. This circuitry can bypass both instant trigger zones, making them seem to stop working.
- Carefully reassemble the under-dash trim panels.
- Inspect the engine compartment for tools that may have been left behind.

TOOLS REQUIRED

This is a general list of tools required to complete the installation of this security system in most vehicles. Some vehicles may require additional tools.

- Digital multi-meter
- Wire cutters/strippers
- Solderless terminal crimpers
- Cordless power drill
- Torx driver set
- Nutdriver and/or socket set
- Panel removal tool
- Drill bit set
- Phillips head screwdriver
- Work light

DECIDING ON COMPONENT LOCATION

Siren

Some things to remember when mounting the siren:

- Keep it away from heat sources. Radiators, exhaust manifolds, turbochargers, and heat shields are all things to avoid.
- Mount it where a thief cannot easily disconnect it, whether the hood is open or shut. Both the siren and it's wires should be difficult to find. This usually involves disguising the wire to look like a factory harness.
- We recommend against grounding the siren to it's mounting screws. Instead, we recommend running both the red and black wires into the passenger compartment and grounding to one common point for all devices. After all, both wires are the same length and come already bonded together. Whenever possible, conceal your wires in the factory harnesses or in the same style loom as the factory.
- When possible, put the siren on the same side of the vehicle as the control module, where it's wires will reach the control module's wires without extending them. Always run the wires through the center of a grommet, never through bare metal!
- Point the siren down so water does not collect in it.

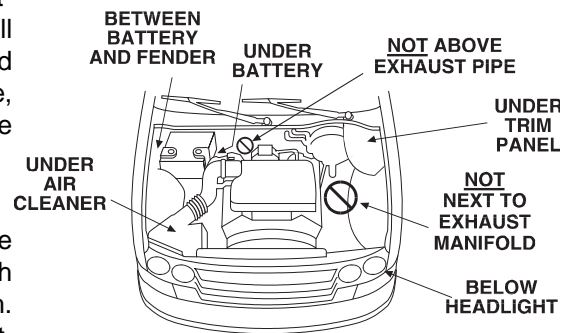

DRW-18

Control Module

Never put the control module in the engine compartment!

The first step in hot-wiring a vehicle is removing the driver's side underdash panel to access the starter and ignition wires. If the control module is placed just behind the driver's side dash it can easily be disconnected.

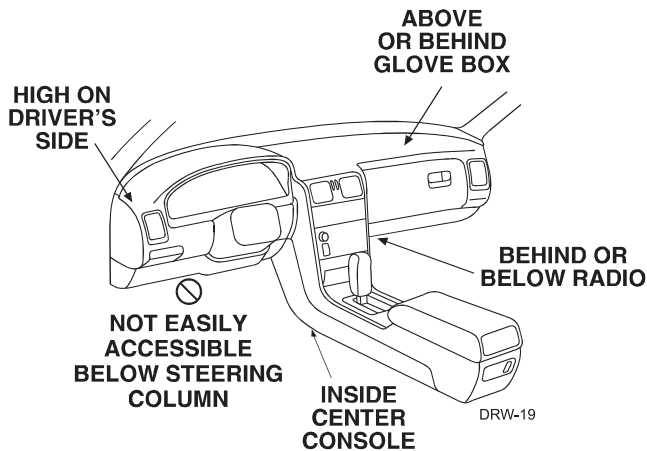

When locating the control module, try to find a secure location that will not require you to extend the harnesses' wires (they are 1.5 meters long). Keep it away from the heater core (or any other heat sources) and any obvious leaks.

The higher the control module is in the vehicle, the better the transmitter range will be. If you put the control module under a seat or inside a metal dashboard, range will suffer.

Some good control module locations: Above the glove box, inside the center console, above the underdash fuse box, above the radio, etc.

Valet/program Switch

Ensure that the location you pick for the switch has sufficient clearance to the rear. The switch should be well hidden. It should be placed so passengers or stored items (such as in a glove box or center console) cannot accidentally hit it. The switch fits in a 9/32" hole.

IMPORTANT! When the vehicle is delivered, please show the user where the switch is located and how to disarm the system with it.

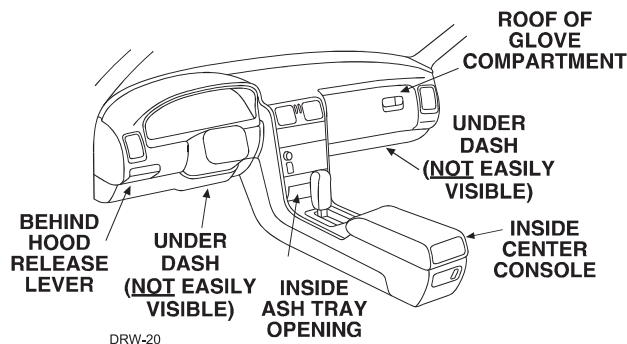

Status LED

Things to remember when positioning the Status LED:

- It should be visible from both sides and the rear of the vehicle, if possible.
- It needs at least 1/2" clearance to the rear.
- It is easiest to use a small removable panel, such as a switch blank or a dash bezel. Remove it before drilling your 9/32" hole.
- Use quick-disconnects near the LED wires if the panel is removable. This allows mechanics or other installers to remove the panel without cutting the wires.

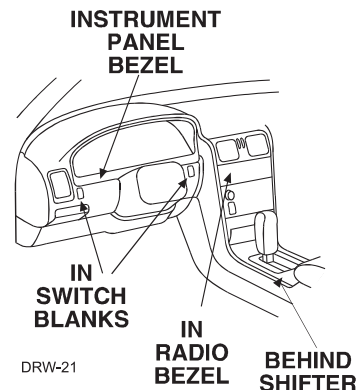

Starter Kill Relay

If the Starter Kill Relay or its connections are immediately visible upon removal of the underdash panel, they can easily be bypassed. Always make the relay and its connections difficult to discern from the factory wiring! Exposed yellow butt connectors do not look like factory parts, and will not fool anyone! For this reason, routing the starter kill wires away from the steering column is recommended.

CONNECTING YOUR WIRES

Now that you have decided where each component will be located, you're going to find the wires in the car that the security system will be connected to.

IMPORTANT! Do not use a 12V test light to find these wires! All testing described in this manual is described using a digital multimeter.

Obtaining Constant 12V

We recommend two possible sources for 12V constant: The (+) terminal of the battery, or the constant supply to the ignition switch. **Always install a fuse within 12 inches of this connection.**

IMPORTANT! Do not remove the fuse holder on the red (H1/11) wire. It ensures that the control module has its own fuse, of the proper value, regardless of how many accessories are added to the main power feed.

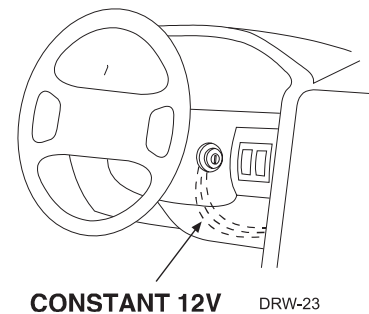
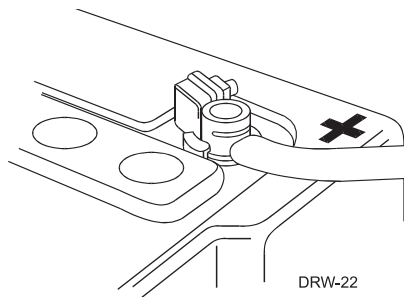
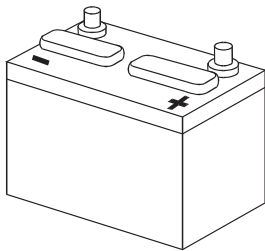

Finding the 12V Switched Ignition Wire

The ignition wire is powered when the key is in the run or start position. This is because the ignition wire powers the ignition system (spark plugs, coil) as well as the fuel delivery system (fuel pump, fuel injection computer). Accessory wires, on the other hand, lose power when the key is in the start position to make more current available to the starter motor.

How to find (+)12V ignition with your multimeter:

1. Set to DCV or DC voltage (12V or 20V is fine).
2. Attach the (-) probe of the meter to chassis ground.
3. Probe the wire you suspect of being the ignition wire. The steering column harness or ignition switch harness is an excellent place to find this wire.
4. Turn the ignition key switch to the run position. If your meter reads (+)12V, go to the next step. If it doesn't, probe another wire.
5. Now turn the key to the start position. The meter display should stay steady, not dropping by more than a few tenths of a volt. If it drops close to or all the way to zero, go back to step 3. If it stays steady at (+)12V, you have found an ignition wire.

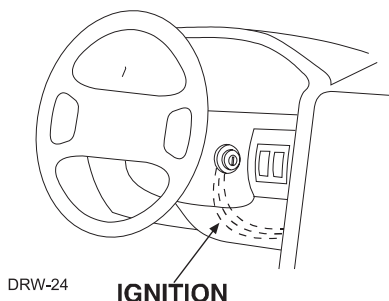

Finding a (+) Parking light Wire

The (+) parking light wire is often found near the switch. Many cars have the switch built into the turn signal lever, and in these cars the parking light wire can be found in the steering column. The same wire is often available in the kick panel or running board.

How to find a (+) parking light flash wire with your multimeter

1. Set to DCV or DC voltage (12V or 20V is fine).
2. Attach the (-) probe of the meter to chassis ground.
3. Probe the wire you suspect of being the parking light wire. Usually, the area near the headlight/parking light switch is an excellent area to start, as is the kick panel.
4. Turn on the parking lights. If your meter shows (+)12V, turn off the parking lights and make sure it goes back to zero.
5. If it does return to zero, turn the parking lights back on and, using the dash light dimmer control, turn the brightness of the dash lights up and down. If the meter changes more than a volt when using the dimmer, look for another wire. If it stays relatively close to (+)12V, you have found your parking light wire.

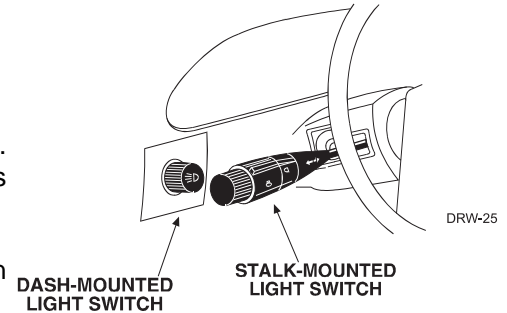

Finding the Door Pin Switch Circuit

The best places to find the door switch wire are:

At the pin switch: When testing at the pin switch, check the wire to ensure that it “sees” all the doors. Often, the passenger switch will cover all the doors even if the driver’s switch will not.

At the dome light: This may not be your best choice if the vehicle has delayed domelight supervision, but it will work in vehicles with completely diode-isolated pin switches.

Once you have determined the wire color, the easiest place to connect to the wire is often at the kick panel, at the windshield pillar, or in the running board. When an easy location is not available, running a wire to the domelight itself is often the best solution.

How to find a door pin switch trigger wire with your multimeter:

1. Set to DCV or DC voltage (12V or 20V is fine).
2. In most cars, fasten the (+) probe of your meter to (+)12V constant.
3. Probe the wire you suspect of being the door trigger wire. If the meter reads (+)12V when any door is opened and the meter goes to 0 with the door closed, you have found a trigger wire.

NOTE: Make sure the wire you use “sees” all the doors! Some newer vehicles lack standard-type pin-switches. The dome light in these vehicles is turned on when the door handle is lifted. These usually have a wire coming out of the door into the kick panel which will provide a (-) trigger for all doors.

Finding the starter wire

How to find the (+)12V starter wire with your multimeter:

1. Set to DCV or DC voltage (12V or 20V is fine).
2. Attach the (-) probe of the meter to chassis ground.
3. Probe the wire you suspect of being the starter wire. The steering column is an excellent place to find this wire. Remember you do not need to interrupt the starter at the same point you test it. Hiding your starter kill relay and connections is always recommended.
4. Turn the ignition key switch to the start position. Make sure the car is not in gear! If your meter reads (+)12V, go to the next step. If it doesn't, probe another wire.
5. Cut the wire you suspect of being the starter wire.
6. Attempt to start the car. If the starter engages, reconnect it and go back to step 3. If the starter does not turn over, you have the right wire.

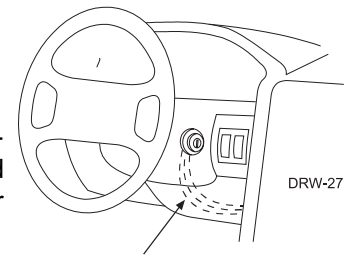

STARTER WIRE

MAKING YOUR CONNECTIONS

When connecting the security system's wires to the wires in the vehicle it is important that the connections are tight and no bare wire is exposed. Shown below are two types of connections that may be used to connect the wires from the security system into the vehicle's wiring. Both types of connections are electrically acceptable if made correctly. Other types of "tap-in" connections, such as T-Taps are not acceptable.

SOLDERLESS BUTT CONNECTIONS

1. Cut the wire and strip back about 1/4" of insulation on each end of the wire.

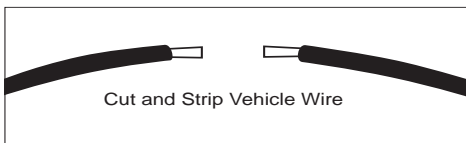

2. Twist one end of the vehicle's wire with the security module's wire.

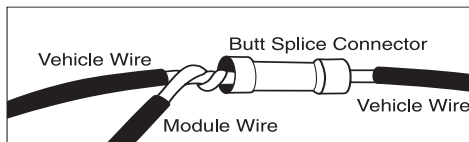

3. Insert the twisted pair of wires into one end of the butt connector and crimp securely.

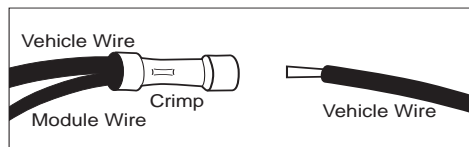

4. Insert the other end of the vehicle's wire into the other end of the butt connector and crimp securely.

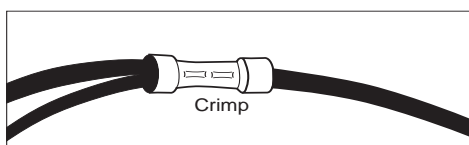

SOLDER CONNECTIONS

1. Using your wire strippers and razor knife, strip about 1/2" of insulation off the wire to be connected to, without cutting the wire.



2. Twist the security module's wire around the bare section of the vehicle's wire.

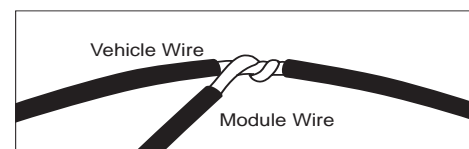

3. Solder the bare connection thoroughly using rosin core solder.

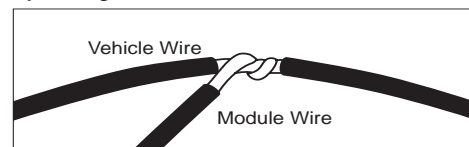

4. Completely insulate the connection with electrical tape.

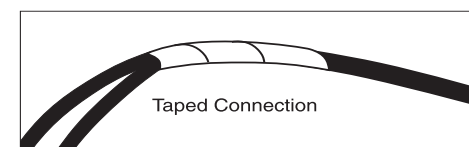

PRIMARY HARNESS H1, 12-PIN CONNECTOR

H1/1	ORANGE	(-) 500 mA ARMED OUTPUT
H1/2	WHITE	(+)/(-) SELECTABLE LIGHT FLASH OUTPUT
H1/3	WHITE/BLUE	(+) TRUNK RELEASE INPUT, SENSOR BYPASS
H1/4	BLACK/WHITE	(-) 200 mA DOMELIGHT SUPERVISION OUTPUT
H1/5	GREEN	(-) DOOR TRIGGER INPUT, ZONE 3
H1/6	BLUE	(-) INSTANT TRIGGER INPUT, ZONE 1
H1/7	VIOLET	(+) DOOR TRIGGER INPUT, ZONE 3
H1/8	BLACK	(-) CHASSIS GROUND INPUT
H1/9	YELLOW	(+) SWITCHED IGNITION INPUT, ZONE 5
H1/10	BROWN	(+) SIREN OUTPUT
H1/11	RED	(+) CONSTANT POWER INPUT
H1/12	RED/WHITE	(-) 200 mA CHANNEL 2 OR DELAYED ACC. OUTPUT

WIRE CONNECTION GUIDE

This guide describes in detail the connection of each wire. Also included are possible applications of each wire. This system was designed with the ultimate in flexibility and security in mind. Many of the wires have more than one possible function. Please read carefully to ensure a thorough understanding of this unit.

Primary Harness, 12-pin connector

H1/1 ORANGE (-) ground-when-armed output: This wire supplies a (-) ground as long as the system is armed. This output ceases as soon as the system is disarmed. This wire controls operation of the pre-wired starter kill relay and can be used to control other optional accessories.

NOTE: If connecting the orange wire to control another module, such as a 529T or 530T window controller, a 1 amp diode (type 1N4004) will be required. Insert the diode as shown below.

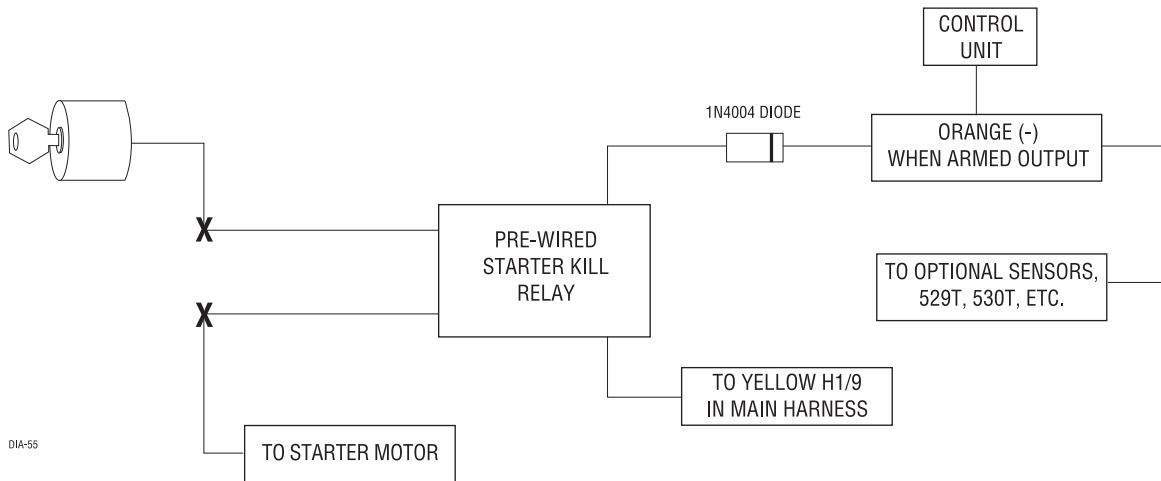

IMPORTANT! Never interrupt any wire other than the starter wire.

H1/2 WHITE light flash output: As shipped, this wire should be connected to the (+) parking light wire. If the light flash polarity jumper inside the unit is moved to the opposite position (see Internal Jumpers, page 17), this wire supplies a (-) 200 mA output. This is suitable for driving (-) parking light wires.

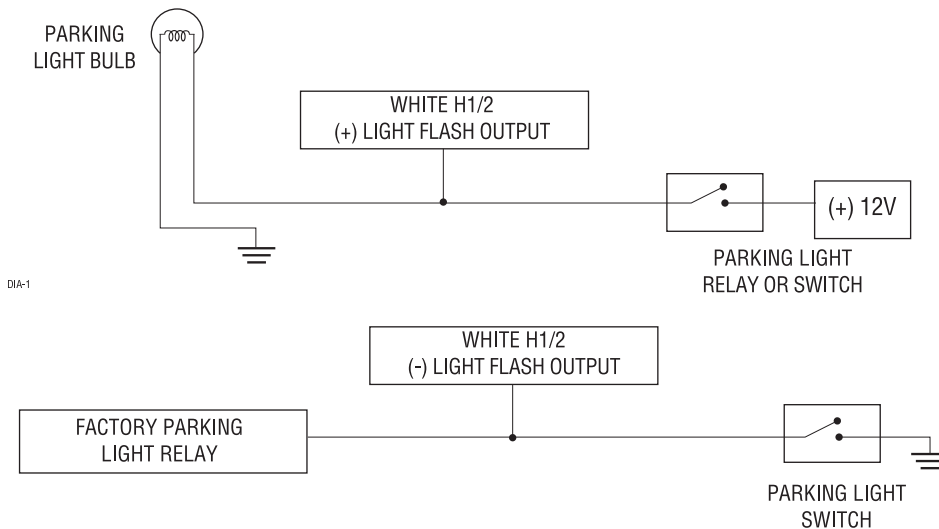

H1/3 WHITE/BLUE (+) trunk release/sensor shunt input: This input is used to bypass sensor inputs when the trunk is opened using the factory transmitter. Connect this wire to the (+) trunk release output of the factory keyless entry system or trunk release relay. When the system receives a (+) input on this wire, zones 2 and 4 are bypassed for three seconds. If during that three seconds, ground is applied to the H1/6 BLUE wire zones 2 and 4 will remain bypassed until the ground input is removed. This means that when the trunk is opened with the factory transmitter the only triggers that remains active while the trunk is open are the doors. Three seconds after the trunk is closed the bypassed zones will become active again.

H1/4 BLACK/WHITE 200 mA (-) domelight-supervision output: Connect this wire to the optional domelight supervision relay.

IMPORTANT! This output is only intended to drive a relay. It cannot be connected directly to the domelight circuit, as the output cannot support the current draw of one or more bulbs.

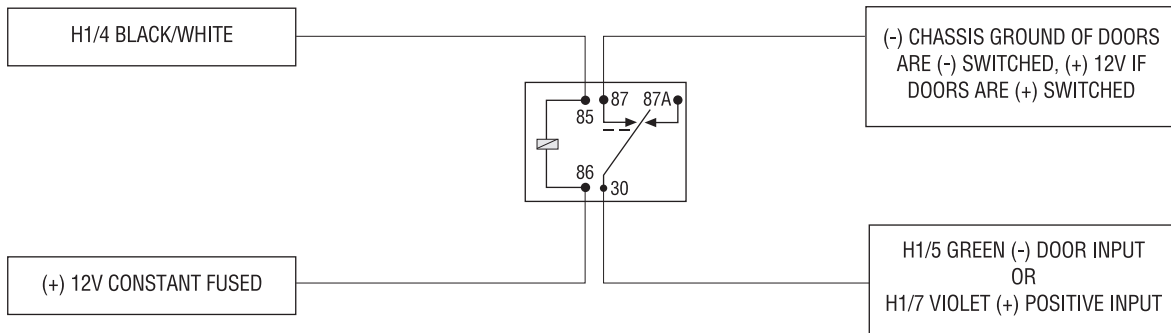

H1/5 GREEN (-) door trigger input: Most vehicles use negative door trigger circuits. Connect the GREEN wire to a wire which shows ground when any door is opened. In vehicles with factory delays on the domelight circuit, there is usually a wire that is unaffected by the delay circuitry.

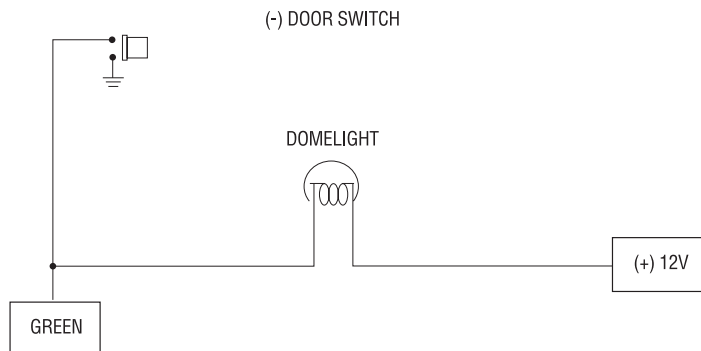

H1/6 BLUE (-) instant trigger: This input will respond to a negative input with an instant trigger. It is ideal for hood and trunk pins and will report on zone one.

H1/7 VIOLET (+) door trigger input: This wire is used in vehicles that have a positive (+) switched dome light circuit. Connect the VIOLET wire to a wire that shows (+)12V when any door is opened, and ground when the door is closed.

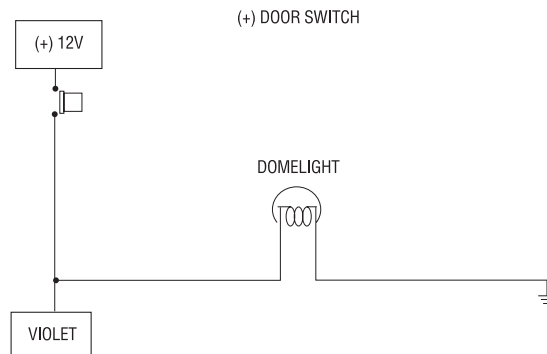

H1/8 BLACK (-) chassis ground connection: Connect this wire to bare metal, preferably with a factory bolt rather than your own screw. Screws tend to either strip or loosen with time. All components, including the siren should be grounded to the same point in the vehicle if possible.

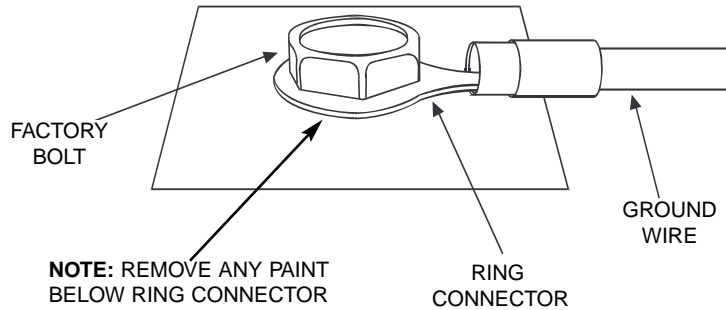

H1/9 YELLOW (+) ignition input: Connect this wire to the (+)12V ignition wire. This wire must show (+)12V with the key in Run position and during cranking. Take care to insure that this wire cannot be shorted to the vehicle chassis at any point.

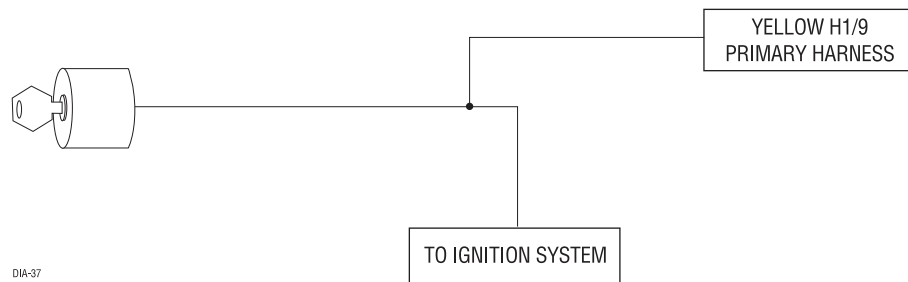

H1/10 BROWN (+) siren output: Connect this to the RED wire of the siren. Connect the BLACK wire of the siren to (-) chassis ground, preferably at the same point you connect the control module's BLACK ground wire.

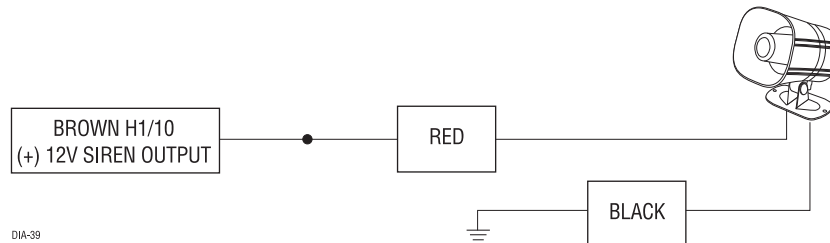

H1/11 RED (+)12V constant power input: Before connecting this wire, remove the supplied fuse. Connect to the battery positive terminal or the constant 12V supply to the ignition switch.

NOTE: Always use a fuse within 12 inches of the point you obtain (+)12V. Do not use the 15A fuse in the harness for this purpose. This fuse protects the module itself.

H1/12 RED/WHITE (-) 200mA auxiliary channel/delayed accessory output: If programmed for an auxiliary output, this wire will provide a (-) pulse when the lock button on the factory transmitter is pressed twice within three seconds. This output can be used to control optional accessories. If programmed for delayed accessory output, this wire will provide (-) ground when the ignition is turned off and will continue to output (-) ground until a door is opened then closed. This can be used to energize the accessory circuit in the vehicle to keep the radio and other accessories on after the ignition is turned off.

IMPORTANT! Never use this wire to drive anything but a relay or a low-current input! This transistorized output can only supply (-) 200 mA, and connecting directly to a solenoid, motor, or other high-current device will cause the module to fail.

5-PIN AUXILIARY PLUG

H3/1 BROWN (-)horn honk output: This wire supplies a 200 mA (-) output that can be used to honk the vehicle's horn. It provides a pulsed output when the security system is in the triggered sequence or in panic mode. In most vehicle's with (-) horn circuits this wire can control the vehicle's horn without adding a relay. If the vehicle has a (+) horn circuit, an optional relay must be used to interface with the vehicle's horn circuit.

IMPORTANT! Never use this wire to drive anything but a relay or a low-current input! This transistorized output can only supply (-) 200 mA, and connecting directly to a solenoid, motor, or other high-current device will cause the module to fail.

H2/2 GREEN arm input: Connect this wire to a wire that changes state when the doors are locked using the factory keyless entry transmitter. This wire can accept a positive (+) or negative (-) input. The vehicle's power door lock motor wire is ideal.

H2/3 RED disarm defeat input: This wire is used to prevent the interior door lock switches from disarming the system. To determine the best location to interface this wire, first test the operation of the remote keyless entry system. When unlocking the doors with the factory remote transmitter, does the driver's door unlock first? Most vehicles operate this way. If this is the case connect the RED wire to the passenger unlock motor wire. When testing this wire be sure that it shows 12V (+) when the unlock button on the factory transmitter is pressed twice. If the factory keyless entry system unlocks all of the doors at the same time, connect this wire to the unlock wire coming from the lock switch.

H2/4 BLUE disarm input: Connect this wire to a wire that changes state when the doors are unlocked using the factory keyless entry transmitter. If the factory transmitter unlocks the driver's door first, the BLUE wire must be connected to the wire that changes state when the driver's door is unlocked by itself. In this case, find the driver's door unlock motor wire. In most vehicle's this wire can be found in the driver's kick panel.

H2/5 WHITE (-) 200mA passive lock output: This wire provides a (-) 200mA pulse when the system passively arms. If passive arming is not enabled this wire has no function. If the customer wants the system to automatically lock the doors when the system passively arms, connect this wire to the lock circuit in the vehicle. An optional relay may be required.

IMPORTANT! Never use this wire to drive anything but a relay or a low-current input! This transistorized output can only supply (-) 200 mA, and connecting directly to a solenoid, motor, or other high-current device will cause the module to fail.

Commonly used motor wire colors:

	<u>Lock</u>	<u>Driver's Unlock</u>	<u>Pass. Unlock</u>
Ford	Pink/Black	Red/Orange	Pink/Orange
General Motors	Gray	Tan or Gray/Black	Tan
Chrysler	Orange/Black	Pink/Black	Pink/Black

There are three main types of keyless entry systems. Systems that unlock the driver's door first and have internal relays, systems that unlock the driver's door first but have external relays, and systems without driver's priority door unlock.

Connecting door lock inputs in vehicles with driver's door unlock from factory remote:

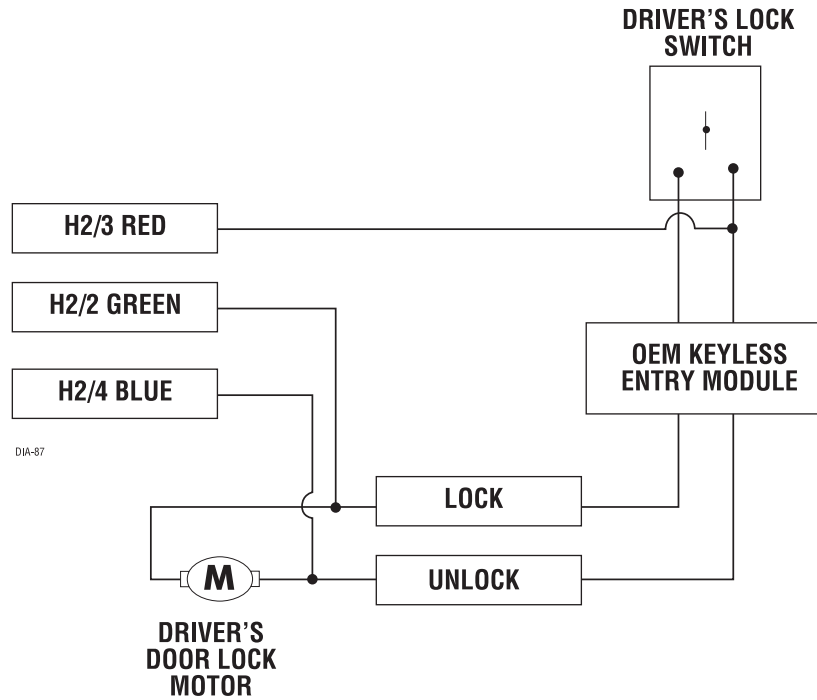

Connecting door lock inputs in vehicles with driver's door unlock and external relays:

This system is used in many four-door GM sedans. To test for this type of system, probe the unlock wire from the interior switch (black or white). Unlock the driver's door, by itself, using the factory remote. If the switch wire shows (+) 12V, then use the following diagram:

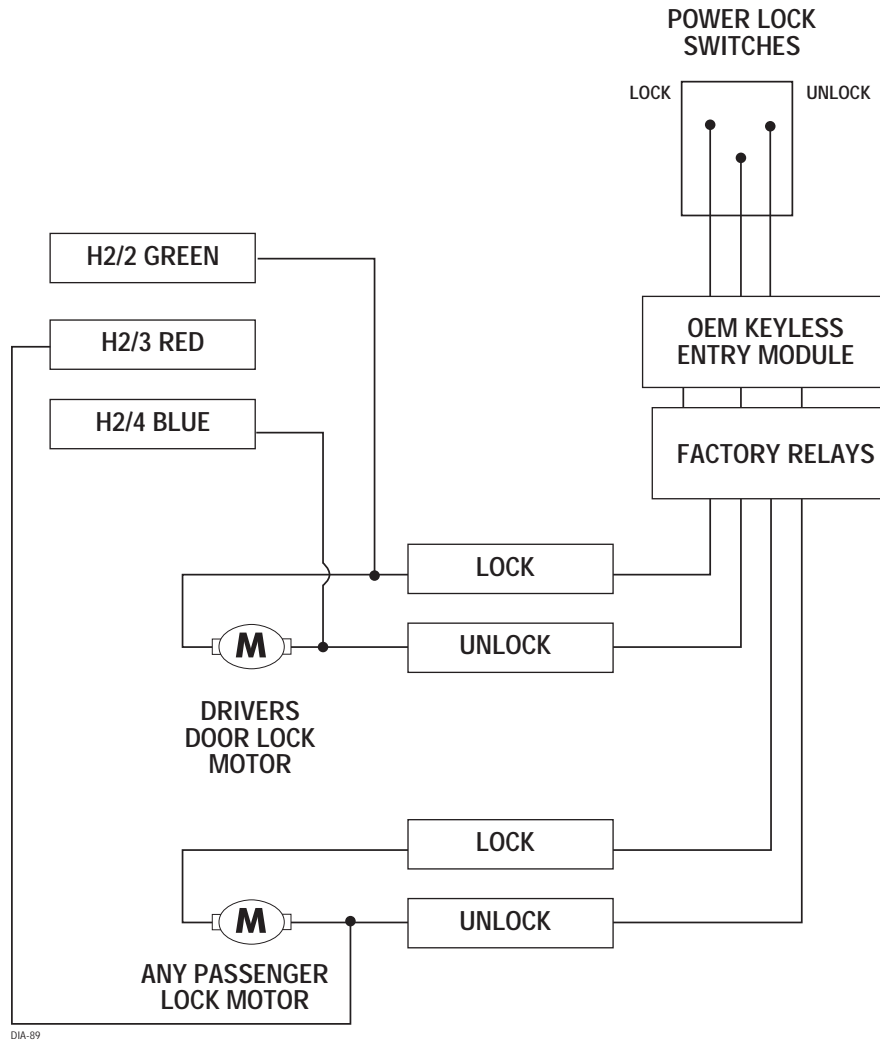

Note: It is often easy to access the passenger unlock wire going to the rear door motor on the driver's side.

DOOR LOCK LEARN ROUTINE

Before the unit will respond to the factory remote keyless system, it must learn the polarity of the door lock wires. To learn the lock polarity:



1. Open the vehicle's door.



2. Turn the ignition to the "on" position.



3. Press and hold the valet button for three seconds.

4. The LED will flash once to confirm the lock polarity was learned.

PLUG-IN HARNESSES

Super Bright LED, 2-pin white plug

The super bright LED operates at 2V DC. Make sure the LED wires are not shorted to ground as the LED will be damaged. The LED fits into a 9/32 inch mounting hole. Be sure to check for clearance prior to drilling the mounting hole.

Valet/program Switch, 2-pin blue plug

The valet/program switch should be accessible from the driver's seat. It plugs into the blue port on the side of the unit. Since the system features valet by remote, the switch can be well hidden. Consider what the switch will be used for before choosing a mounting location. Check for rear clearance before drilling a 9/32 inch hole and mounting the switch. The GRAY wire in the two-pin plug may also be used as a (+) ghost switch input and can be connected to any (+) switch in the vehicle (see Feature Descriptions, page 20).

NOTE: Please note for the customer the location of the valet/program switch in the section provided in the Owner's Guide.

ON-BOARD STINGER DOUBLEGUARD SHOCK SENSOR

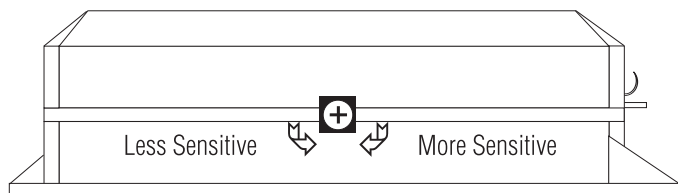

DRW-52

There is a dual-stage shock sensor inside the control unit. Adjustments are made via the rotary control as indicated above. Since the shock sensor does not work well when mounted firmly to metal, we recommend against screwing down the control module. The full trigger of the onboard shock sensor reports zone 2. See Table of Zones page 21.

NOTE: When adjusting the sensor, it must be in the same mounting location that it will be after the install is completed. Adjusting the sensor and then relocating the module requires readjustment.

INTERNAL PROGRAMMING JUMPER

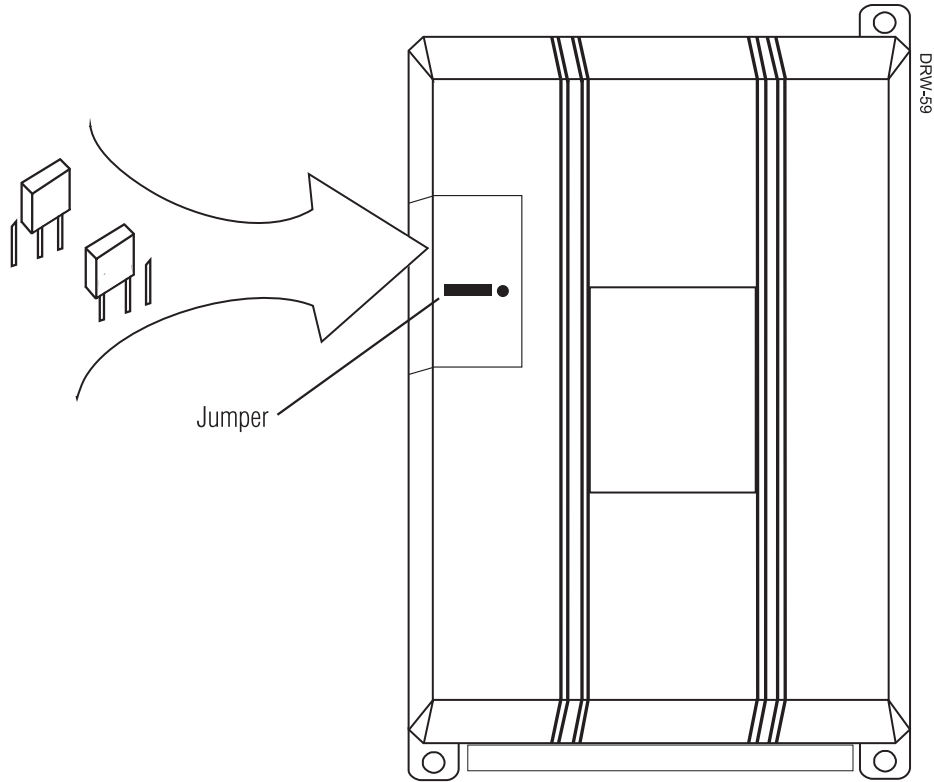

(-) Light flash output ●●● (+) Light flash output

LIGHT FLASH JUMPER: This jumper is used to determine the light flash output. In the (+) position, the on-board relay is enabled and the unit will output (+)12V on the WHITE wire, H1/2. In the (-) position, the on-board relay is disabled. The WHITE wire, H1/2, will supply a 200 mA (-) output suitable for driving factory parking light relays. To access the jumper, remove the sliding door from on top of the control module.

SYSTEM FEATURES LEARN ROUTINE

The System Features Learn Routine dictates how the unit operates. It is possible to access and change any of the feature settings using the valet/program switch.

To enter the System Features Learn Routine:

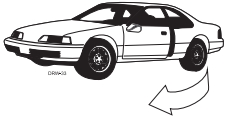

1. Open a door: The GREEN wire, H1/5, or the VIOLET, H1/7 must be connected.



2. Turn the ignition on, then off: The YELLOW wire, H1/9 must be connected.



4. Select a feature: Press and release the valet/program button the number of times corresponding to the step you wish to change. For example, to access the third feature, press and release three times. Then press the button once more and HOLD it. The siren will chirp the number of times equal to the step you have accessed.

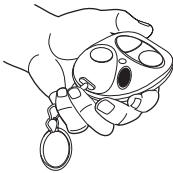

5. Program the feature: While holding the valet/program button, you can toggle the feature on and off using your factory remote transmitter. Pressing the button that locks the doors will select the one chirp or default setting. Pressing the button that unlocks the doors, will select the two chirp setting.

NOTE: The valet pulse count feature (8) has five possible settings. Pressing unlock will toggle through all the possible settings.

6. Release the valet/program button.

System Features Menu:

Step	One Chirp (Default)	Two Chirps
1	Active arming	Passive arming
2	Audible arm/disarm confirmation on	Audible Arm/disarm confirmation off
3	Siren duration 30 seconds	60 seconds
4	Instant door trigger	Delayed door trigger
5	Door trigger error chirp ON	Door trigger error chirp OFF
6	Sensor shunt zones 2 and 4	All zones
7	Panic enabled	Auxiliary output enabled
8	No function	No function
9	Valet switch input: 1 pulse	Valet switch input: 2-5 pulses

Once the feature is programmed:

- Other features can be programmed.
- The Learn Routine can be exited if programming is complete.

To access another feature

Press and release the valet/program button the number of times necessary to advance from the feature you just programmed to the next one you want to program. Then press the valet/program button once more and hold it. For example, if you just programmed the second feature and you would like to program the seventh feature in the menu, you would: Press and release the valet/program button five times. Then press it once more and hold it. The siren would chirp seven times to confirm access to the seventh feature.

To exit the learn routine

Do one of the following:

1. Close the open door.
2. Turn the ignition on.
3. No activity for longer than 15 seconds.
4. Press the valet/program button too many times.

FEATURES DESCRIPTIONS

1 ACTIVE/PASSIVE ARMING: When active arming is selected, the system will only arm when the transmitter is used. When set to passive, the system will arm automatically 30 seconds after the last door is closed. To alert the consumer of passive arming, the siren will chirp and the parking lights will flash 30 seconds after the door is closed.

2 AUDIBLE ARM/DISARM CONFIRMATION ON/OFF: This feature controls the chirps that confirm the arming and disarming of the system. In the ON setting (default) the siren will provide audible confirmation when arming and disarming the system. If programmed to the OFF position no siren chirps will be heard when arming and disarming.

3 SIREN DURATION 30/60 SECONDS: In the default setting, the full triggered sequence will continue when triggered for 30 seconds. This can be changed to 60 seconds in the system features learn routine.

4 DOOR TRIGGER INSTANT/DELAYED: In the instant (default) setting, if a door is opened while the security system is armed the system will trigger immediately. In the delayed setting there is a 15 second delay before the doors will trigger the system. This gives the user 15 seconds to disarm the system after a door is opened without the factory transmitter.

5 DOOR TRIGGER ERROR CHIRP ON/OFF: With the door trigger error chirp programmed off, the system will not report an invalid zone on arming when the door trigger wire is active. This eliminates the extra chirps that occur when interfacing with vehicles that have exceptionally long dome light delay circuits.

6 SENSOR SHUNT ZONES 2 AND 4/ALL ZONES: In the default setting, all sensors with the exception of the door zone will be bypassed when a trigger is grounded three seconds after a (+) pulse on the white/blue (trunk is opened). If programmed to the all zones setting, all zones including the doors will be bypassed when the trunk is opened with the factory transmitter.

7 PANIC/AUXILIARY OUTPUT: In the default setting, pressing the lock button on the factory transmitter twice within three seconds will trigger panic mode. If programmed to the auxiliary output setting, pressing the lock button twice within three seconds will send a (-) pulse on the RED/WHITE auxiliary output wire.

8 NO FUNCTION

9 VALET PULSE COUNT 1-5 PULSES: The system can be programmed to count the number presses of the valet switch before disarming the security system. The factory default setting is one pulse. The unit can be set for 2-5 pulses using Button II to select the setting.

Ghost Switch option: For added security, the **GRAY** wire on the two-pin valet/program can be connected to any switch in the vehicle that provides a positive (+) momentary pulse.

TABLE OF ZONES

When using the diagnostic functions, use the Table of Zones to see what input has triggered the system. It is also helpful in deciding what input to use when connecting optional sensors and switches

<u>Zone #</u>	<u>Trigger Type</u>	<u>Input Description</u>
One	Instant	H1/6 BLUE wire. Connect to optional hood/trunk pins
Two	Multiplexed	Heavy impact detected by the on-board dual-stage shock sensor.
Three	Two-stage, progresses from warning to full alarm	Door switch circuit. H1/5 GREEN or H1/7 VIOLET.
Four	Multiplexed	Optional sensor, BLUE and GREEN wires on the 4-pin sensor plug.
Five	Two-stage (similar to doors)	Ignition input. H1/9 YELLOW.

The warn away response does not report on the LED.

RAPID RESUME LOGIC

This DEI system will store its current state to non-volatile memory. If power is lost and then reconnected the system will recall the stored state from memory. This means if the unit is in valet mode and the battery is disconnected for any reason, such as servicing the car, when the battery is reconnected the unit will still be in valet mode. This applies to all states of the system including arm, disarm, and valet mode.

TROUBLESHOOTING

Starter kill doesn't work:

Is the correct starter wire being interrupted? If the car starts when the starter kill relay is completely disconnected, the wrong starter wire has been interrupted.

YELLOW wire is not connected to true ignition. It is connected to an accessory circuit.

Shock sensor doesn't trigger the alarm:

Has Prevention[®] Circuitry. NPC[™] been triggered? If so, you will hear five chirps when disarming. To check this, turn the ignition key on and off to clear NPC[™] memory, and then retest the shock sensor. For a detailed description, see Owner's Guide.

Door input does not immediately trigger full alarm. Instead, first I hear chirps for three seconds:

That's how the progressive two-stage door input works! This is a feature of this system. This is an instant trigger, remember, since even if the door is instantly closed, the progression from chirps to constant siren will continue.

Closing the door triggers the system, but opening the door does not:

Have you correctly identified the type of door switch system? This happens often when the wrong door input has been used.(refer to page 6)

System will not passively arm until it is remotely armed and then disarmed:

Are the door inputs connected? Is a BLUE wire connected to the door trigger wire in the vehicle? Either the GREEN H1/5 or the VIOLET H1/7 should be used instead.

Door input does not respond with the progressive trigger, but with immediate full alarm:

What zone does the LED indicate? If the LED indicates that the impact sensor caused the trigger, the sensor may be detecting the door opening. Reducing the sensitivity or relocating the control module can often solve this problem.

The valet switch doesn't work.

Is it plugged into the correct socket?

Check the System Features Learn Routine for the programmed Valet pulse count.

Status LED doesn't work.

Make sure that it is plugged in. See page 16. Is the LED plugged into the correct socket?