

Changes for the 05H Chip

VIPER[®] 500HF AUTO SECURITY

INSTALLATION GUIDE

Table of Contents

Experienced security installers may skip to Pg. 8, but read all the italicized sections, as they describe changes and/or new features.

Installation points to remember	Page 2
Deciding on component location	Page 3
Finding the wires you need.....	Page 5
Step-by-step meter instructions!	Page 5
Making your wire connections	Page 7
Primary Harness diagram	Page 8
Wire connection guide	Page 9
Light Flash (+)/(-) and Valet[®]/Program jumpers ..	Page 9
Plug in LED and Valet [®] /Program Switch	Page 11
Four-pin Shock Sensor Harness,	Page 11
new multiplex inputs	Page 11
Bypassing sensor inputs	Page 12
Door lock wiring diagrams	Page 12-15
Transmitter/Receiver Learn Routine™	Page 16
Two-vehicle operation with single transmitter.....	Page 17
Operating-settings Learn Routine™	Page 18
Feature descriptions	Page 20
Final testing,	Page 21
Improved Nuisance Prevention Circuitry™	Page 21
Valet [®] Mode	Page 21
Table of Zones	Page 22
Vehicle Recovery System (VRS [®]) installation	Page 22
Troubleshooting	Page 23



Directed Electronics, Inc.

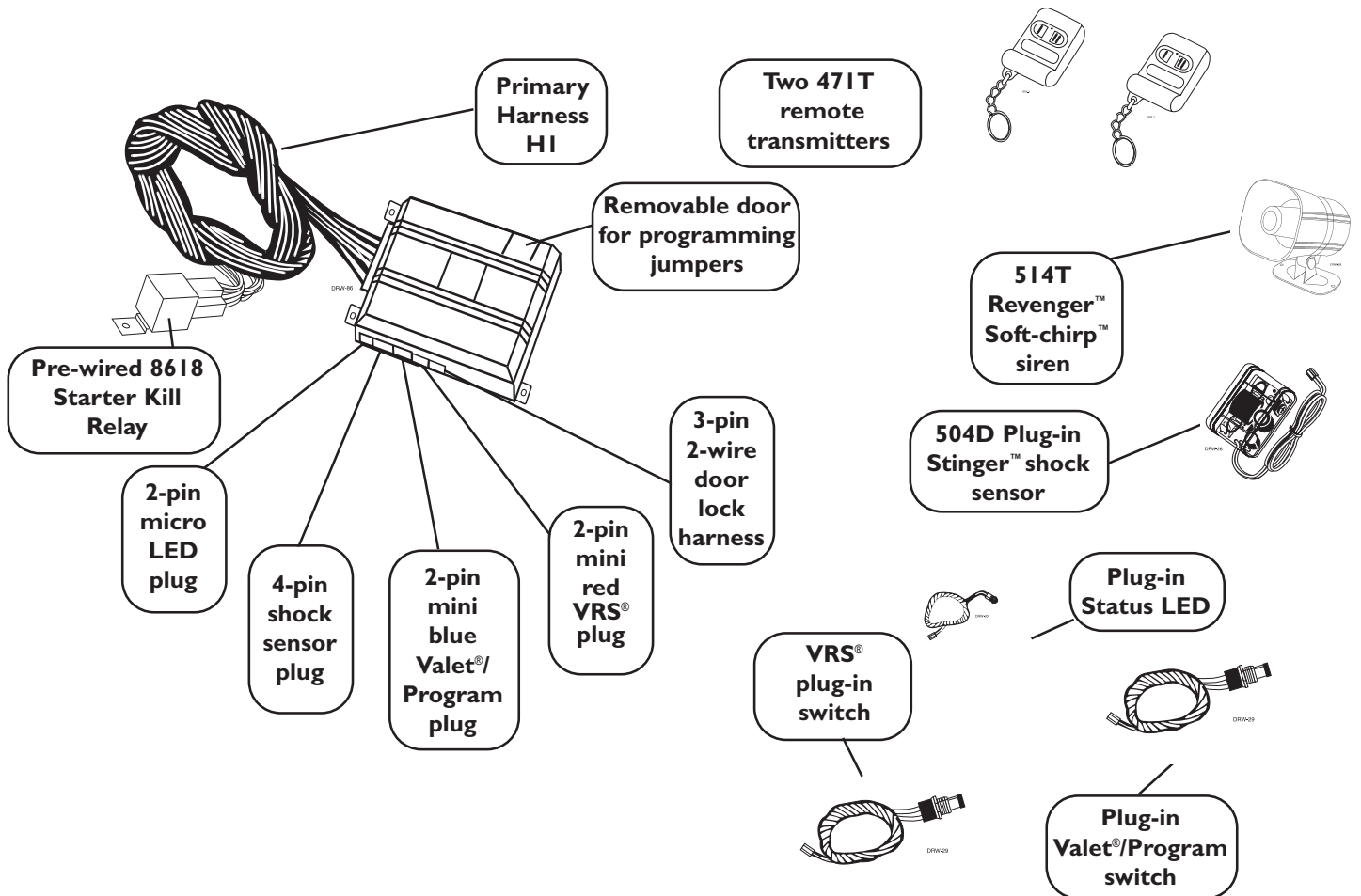

INSTALLATION POINTS TO REMEMBER

Do not disconnect the battery if the vehicle has an anti theft-coded radio. If equipped with an airbag, avoid disconnecting the battery if possible.

IMPORTANT: Many airbag systems will display a diagnostic code through their warning light after they lose power. Disconnecting the battery requires this code to be erased, a procedure that can require a trip to the dealer.

Before beginning the installation:

- Check with the customer on Status LED location.
- Remove the domelight fuse. This prevents accidentally draining the battery.
- Roll down a window to avoid being locked out of the car.

After the install:

- Test all functions. The "Using Your System" section of the Owner's Guide is very helpful when testing.
- When testing, don't forget that this system is equipped with Nuisance Prevention Circuitry™. NPC™ can bypass trigger zones, making them appear to stop working. See Final Testing, page 21.

Step One: Deciding on component locations.

Siren

Some things to remember about where to mount the siren:

1. Keep it away from heat sources. Radiators, exhaust manifolds, turbochargers, and heat shields are all things to avoid.
2. Mount it where a thief cannot easily disconnect it, whether the hood is open or shut. Both the siren and its wires should be difficult to find. This usually involves disguising the wire to look like a factory harness.
3. We recommend against grounding the siren to its mounting screws. Instead, we recommend running both the red and black wires into the passenger compartment and grounding to one common point for all devices. After all, both wires are the same length and come already bonded together. Whenever possible, conceal your wires in the factory harnesses or in the same style loom as the factory.
4. When possible, put the siren on the same side of the vehicle as the control module, where its wires will reach the control module's wires without extending them. **Always** run the wires through the center of a grommet, **never** through bare metal!
5. Point the siren down so water does not collect in it.

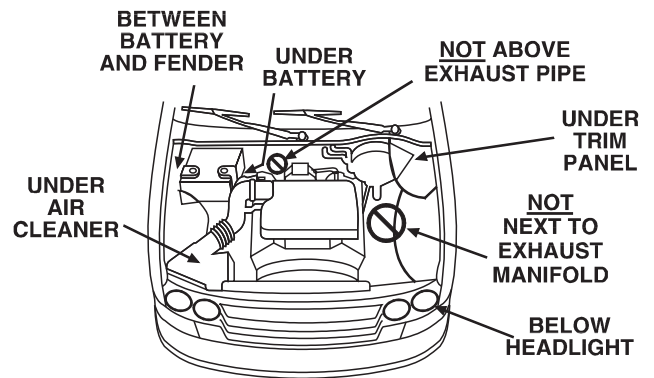

DRW-18

Control Module

Never put the control module in the engine compartment!

The first step in hot-wiring a vehicle is removing the driver's side underdash panel to access the starter and ignition wires. If the control module is placed just behind the driver's side dash it can easily be disconnected.

When locating the control module, try to find a secure location that will not require you to extend the harnesses' wires (they are 1.5 meters long). Keep it away from the heater core (or any other heat sources) and any obvious leaks.

The higher the control module is in the vehicle, the better the transmitter range will be. If you put the control module under a seat or inside a metal dashboard, range will suffer, and you may wish to add a 542H Range Extending Antenna (available separately).

Some good control module locations: above the glove box, inside the center console, above the underdash fuse box, above the radio, etc.

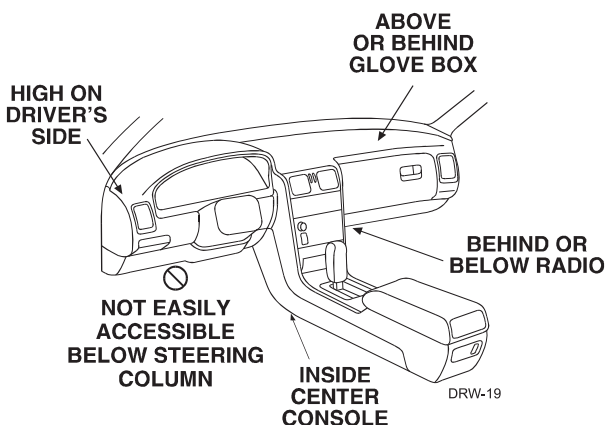

DRW-19

Stinger™ Double-Guard® shock sensor

Never put the Stinger™ shock sensor in the engine compartment!

Find a spot close to the control module so that the wires do not need to be extended. Keep it away from the heater core (or any other heat sources) and any obvious leaks.

How the Stinger™ is mounted is the most important factor in its performance. We recommend two mounting methods: using double-sided tape or hook-and-loop fastener to mount to a trim panel or an air duct, or wire-tying to a wire harness. If mounting the sensor where it cannot be easily reached for adjustment, hook-and-loop fastening tape (such as Velcro) is recommended for ease of removal for future adjustments.

NOTE: In many vehicles, tying the sensor to a steering column or screwing it to metal will result in poor sensitivity, especially on the rear of the vehicle.

Valet® /Program and optional VRS® switches

Ensure that the location you pick for each switch has sufficient clearance to the rear. The switches should be well hidden. They should be placed so passengers or stored items (such as in a glove box or center console) cannot accidentally hit them. The switches fit in a 9/32"-hole.

This system has Remote Valet®. The user can enter and exit Valet® Mode without having to reach the Valet®/Program switch. DEI® introduced this feature so that switch location was less critical in day-to-day use. As long as the Valet®/Program switch can be reached to disarm without a transmitter, easy access is not important.

IMPORTANT! When the vehicle is delivered, please show the user where the switches are located and how to disarm the system and the VRS® feature with them.

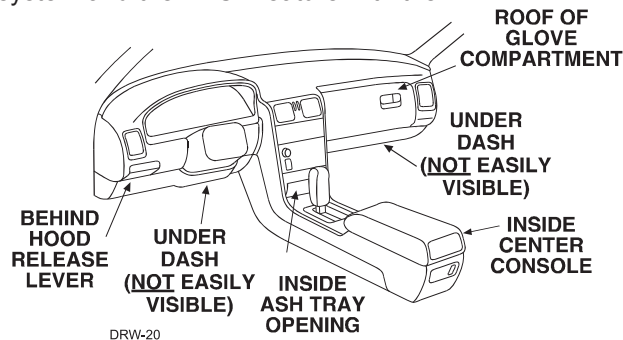

Status LED

Things to remember when positioning the Status LED:

- It should be visible from both sides and the rear of the vehicle, if possible.
- It needs at least 1/2" clearance to the rear.
- It is easiest to use a small removable panel, such as a switch blank or a dash bezel. Remove it before drilling your 9/32" hole.
- Use quick-disconnects near the LED wires if the panel is removable. This lets mechanics or other installers remove the panel without cutting the wires.
- If the optional VRS® feature is being installed, the Status LED must be visible from the driver's seat while the transmission is in gear!

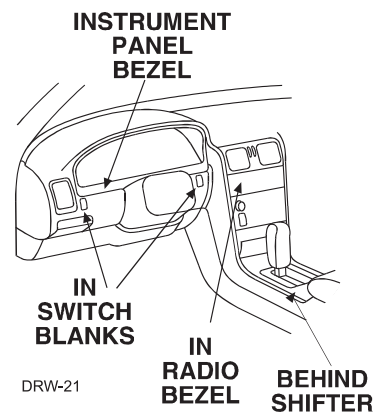

Starter kill relay

If the starter kill relay or its connections are immediately visible upon removal of the underdash panel, they can easily be bypassed. Always make the relay and its connections difficult to discern from the factory wiring! Exposed yellow butt connectors do not look like factory parts, and will not fool anyone! For this reason, routing the starter kill wires away from the steering column is recommended.

Step 2: Finding the wires you need

Now that you have decided where each component will be located, you're going to find the wires in the car that the security system will be connected to.

IMPORTANT: Do not use a 12V test light to find these wires! All testing described in this manual is described using a digital multimeter.

Obtaining constant 12V

We recommend two possible sources for 12V constant: the (+) terminal of the battery, or the constant supply to the ignition switch. **Always install a fuse within 12 inches of this connection.** If the fuse also will be powering other circuits, such as door locks, a power window module, a Nite-Lite® headlight control system, etc.; fuse accordingly.

IMPORTANT: Do not remove the fuse holder on the red wire. It ensures that the control module has its own fuse, of the proper value, regardless of how many accessories are added to the main power feed.

Finding the 12V switched ignition wire

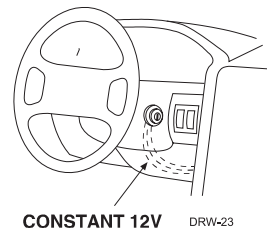
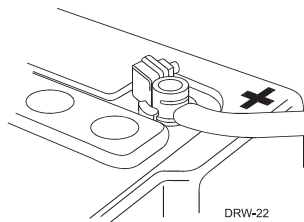
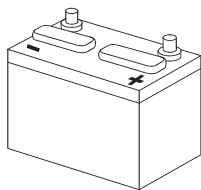

The ignition wire is powered when the key is in the run or start position. This is because the ignition wire powers the ignition system (spark plugs, coil) as well as the fuel delivery system (fuel pump, fuel injection computer). Accessory wires, on the other hand, lose power when the key is in the start position to make more current available to the starter motor.

How to find (+)12V ignition with your multimeter:

1. Set to DCV or DC voltage (12V or 20V is fine).
2. Attach the (-) probe of the meter to chassis ground.
3. Probe the wire you suspect of being the ignition wire. The steering column harness or ignition switch harness is an excellent place to find this wire.
4. Turn the ignition key switch to the run position. If your meter reads (+)12V, go to the next step. If it doesn't, probe another wire.
5. Now turn the key to the start position. The meter display should stay steady, not dropping by more than a few tenths of a volt. If it drops close to or all the way to zero, go back to step 3. If it stays steady at (+)12V, you have found an ignition wire.

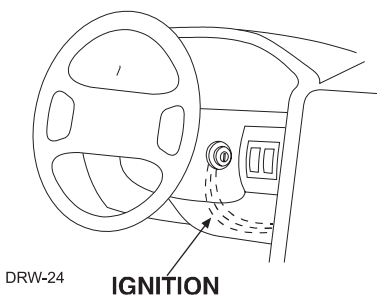

Finding a (+) parking light wire

The (+) parking light wire is often found near the switch. Many cars have the switch built into the turn signal lever, and in these cars the parking light wire can be found in the steering column. The same wire is often available in the kick panel or running board.

NOTE: Many Toyotas, as well as many other Asian vehicles, send a (-) signal from the switch to a relay. The relay then sends 12V(+) to the bulbs. Whenever you have difficulty finding a (+) parking light wire near the switch, simply test the wires at any switch or control panel which is lit by the instrument panel lighting. Remember, you need a (+) parking light wire that does not vary with dimmer setting.

How to find a (+) parking light flash wire with your multimeter

1. Set to DCV or DC voltage (12V or 20V is fine).
2. Attach the (-) probe of the meter to chassis ground.
3. Probe the wire you suspect of being the parking light wire. Usually, the area near the headlight/parking light switch is an excellent area to start, as is the kick panel.
4. Turn on the parking lights. If your meter shows (+)12V, turn off the parking lights and make sure it goes back to zero.
5. If it does return to zero, turn the parking lights back on and, using the dash light dimmer control, turn the brightness of the dash lights up and down. If the meter changes more than a volt when using the dimmer, look for another wire. If it stays relatively close to (+)12V, you have found your parking light wire.

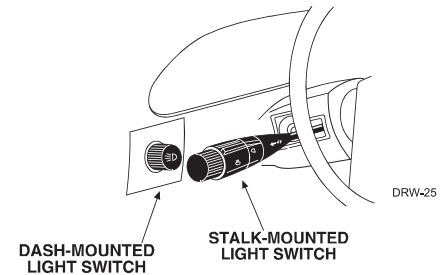

Finding the door pin switch circuit

The best places to find the door switch wire are:

At the pin switch: When testing at the pin switch, check the wire to ensure that it “sees” all the doors. Often, the passenger switch will cover all the doors even if the driver’s switch will not.

At the dome light: This may not be your best choice if the vehicle has delayed domelight supervision, but it will work in many Hondas, or any vehicle with completely diode-isolated pin switches.

Once you have determined the wire color, the easiest place to connect to the wire is often at the kick panel, at the windshield pillar, or in the running board. When an easy location is not available, running a wire to the domelight itself is often the best solution.

How to find a door pin switch trigger wire with your multimeter:

1. Set to DCV or DC voltage (12V or 20V is fine).
2. In most Fords, fasten the (-) probe of the meter to chassis ground. In most other cars, fasten the (+) probe of your meter to (+)12V constant.
3. Probe the wire you suspect of being the door trigger wire. If the meter reads (+)12V when any door is opened, you have found a trigger wire.

NOTE: Make sure the wire you use “sees” all the doors! Some newer GM vehicles lack standard-type pin switches. The dome light in these vehicles is turned on when the door handle is lifted. These usually have a blue/white or white coming out of the door into the kick panel which will provide a (-) trigger for all doors. Some GM vehicles (some Cavaliers, Grand Ams, etc.) have a yellow wire coming out of the door which provides a (+) door trigger.

Finding the starter wire

1. Set to DCV or DC voltage (12V or 20V is fine).
2. Attach the (-) probe of the meter to chassis ground.
3. Probe the wire you suspect of being the starter wire. The steering column is an excellent place to find this wire. Remember you do not need to interrupt the starter at the same point you test it. Hiding your starter kill relay and connections is always recommended.
4. Turn the ignition key switch to the start position. Make sure the car is not in gear! If your meter reads (+)12V, go to the next step. If it doesn't, probe another wire.
5. Cut the wire you suspect of being the starter wire.
6. Attempt to start the car. If the starter engages, reconnect it and go back to step 3. If the starter does not turn over, you have the right wire.

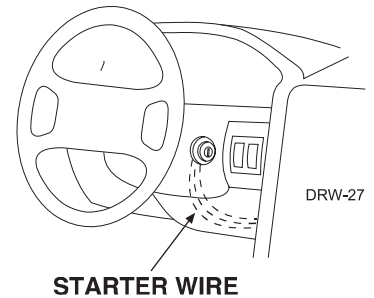

Step 3:

Making your wire connections

Before making your connections, plan how your wires will be routed through the vehicle. For instance, the yellow ignition input, the red 12V constant input, and the orange ground-when-armed output (for the optional starter kill relay) will often be routed together to the ignition switch harness. In order to keep the wiring neat and make it harder to find, you may wish to wrap these wires together in electrical tape or conceal them in tubing similar to what the manufacturer used.

There are two acceptable ways of making a wire connection: solder connections and crimp connectors. When properly performed, either type of connection is reliable and trouble-free. Regardless of whether you solder your connections or you use mechanical-type crimp-on connections, ensure that all connections are mechanically sound and that they are insulated.

Cheap electrical tape, especially when poorly applied, is not a reliable insulator. It often falls off in hot weather. Use good-quality electrical tape or heat shrink.

Never twist-and-tape the wires together without soldering.

Never use "fuse taps", as they can damage fuse box terminals.

If you use tapping connectors such as T-Taps (not to be confused with Scotch-Loks), avoid using them in higher-current applications (constant 12V, ground, etc.). Some tapping connectors are inferior in quality and should be avoided.

PRIMARY HARNESS H1, 12-PIN CONNECTOR

H1/1	ORANGE	(-) 500 mA ARMED OUTPUT
H1/2	WHITE	(+)/(-) SELECTABLE LIGHT FLASH OUTPUT
H1/3	WHITE/BLUE	(-) 200 mA CHANNEL 3 VALIDITY OUTPUT
H1/4	BLACK/WHITE	(-) 200 mA DOMELIGHT SUPERVISION OUTPUT
H1/5	GREEN	(-) DOOR TRIGGER INPUT, ZONE 3
H1/6	BLUE	(-) INSTANT TRIGGER INPUT, ZONE 1
H1/7	VIOLET	(+) DOOR TRIGGER INPUT, ZONE 3
H1/8	BLACK	(-) CHASSIS GROUND INPUT
H1/9	YELLOW	(+) SWITCHED IGNITION INPUT, ZONE 5
H1/10	BROWN	(+) SIREN OUTPUT
H1/11	RED	(+) CONSTANT POWER INPUT
H1/12	RED/WHITE	(-) 200 mA CHANNEL 2 VALIDITY OUTPUT

WIRE CONNECTION GUIDE

H1/1 ORANGE (-) ground-when-armed output: This wire supplies a (-) 500 mA ground as long as the system is armed. This output ceases as soon as the system is disarmed. The orange wire is pre-wired to control the 8618 starter kill relay.

NOTE: If connecting the orange wire to control another module, such as a 529T or 530T window controller, a 1 amp diode (type 1N4004) will be required. Insert the diode as shown below.

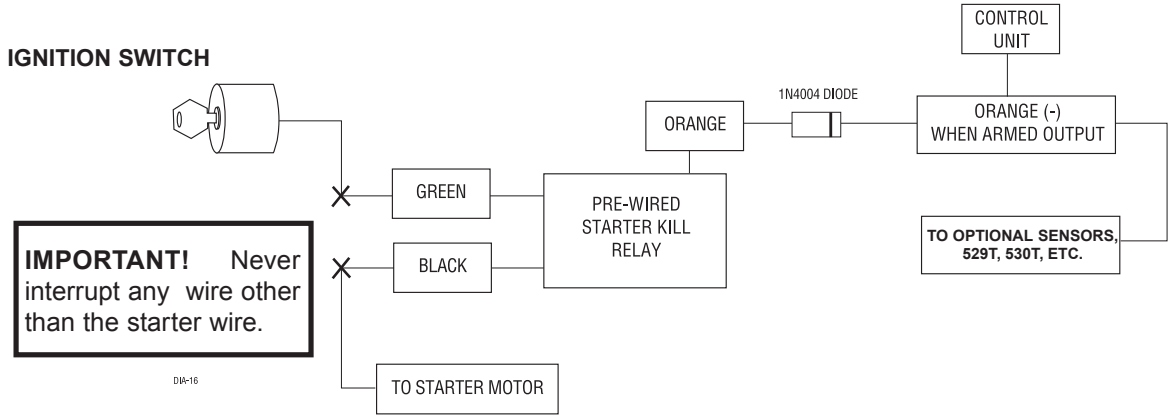

H1/2 WHITE (+/-) light flash output: As shipped, this wire should be connected to the (+) parking light wire. If the light flash polarity jumper under the sliding door is moved to the opposite position (see below), this wire supplies a (-) 200 mA output. This is suitable for driving (-) light control wires in Toyota, Lexus, BMW, some Mitsubishi, some Mazda, etc.

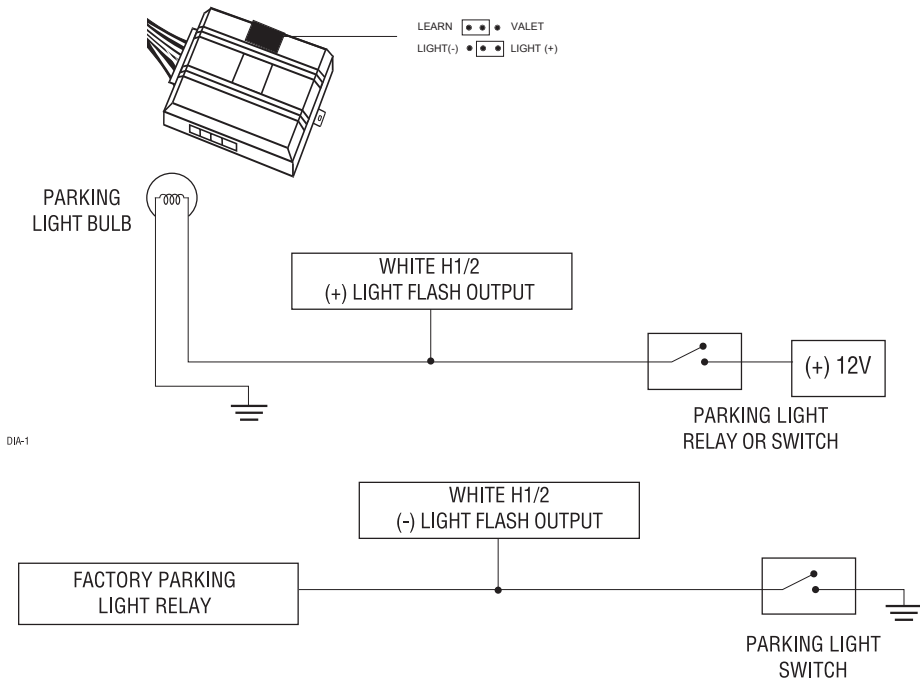

H1/3 WHITE/BLUE channel 3 (-) output: This wire provides a (-) 200 mA signal whenever the transmitter code controlling channel 3 is received. This signal will continue as long as that transmission is received. Use for options such as the 551T Valet® Start system, the 529T or 530T power window controllers, etc.

IMPORTANT! Never use this wire to drive anything but a relay or a low-current input! The transistorized output can only provide 200 mA of current, and connecting directly to a solenoid, motor, or other high-current device will cause it to fail.

H1/4 BLACK/WHITE (-) 200 mA domelight-supervision output: Connect this wire to the optional domelight supervision relay as shown below:

IMPORTANT: This output is only intended to drive a relay. It cannot be connected directly to the domelight circuit, as the output cannot support the current draw of one or more light bulbs.

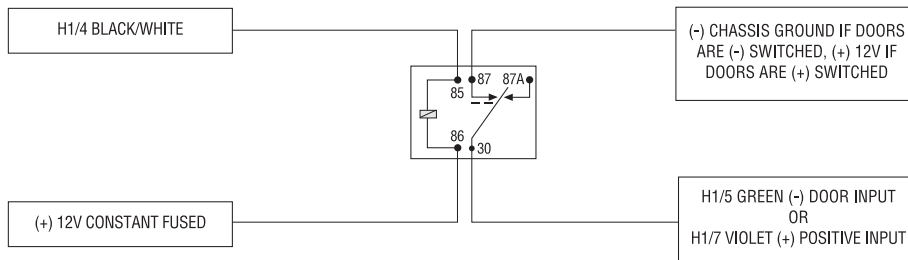

H1/5 GREEN (-) door trigger or **H1/7 VIOLET** (+) door trigger input: If the door switch wire you found is (-) when the door is open, connect the GREEN wire to it. If the door switch wire you found is (+) when the door is open, use the VIOLET wire instead.

IMPORTANT! Test to make sure this wire "sees" all doors!

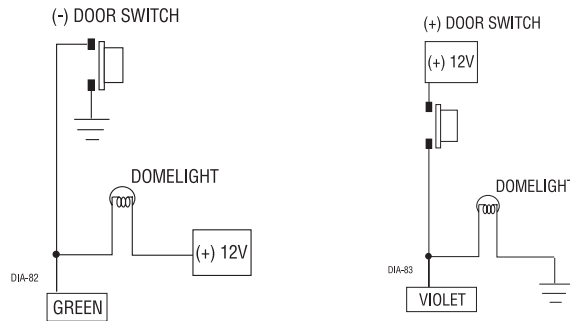

H1/6 BLUE (-) instant trigger: This input will respond to a (-)input with an instant trigger. It is ideal for hood and trunk pins and will report on zone one.

H1/8 BLACK (-) chassis ground connection. Connect this wire to bare metal, preferably with a factory bolt rather than your own screw (screws tend to either strip or loosen with time). We recommend grounding all your components to the same point in the vehicle.

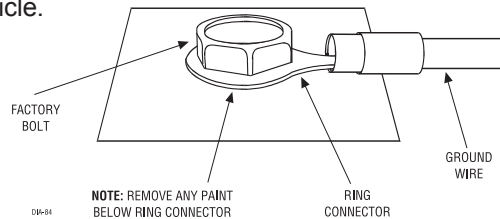

H1/9 YELLOW (+) ignition input. Connect this wire to an ignition wire as described on page 5. This wire must show +12V with the key in run position and during cranking. Take care to insure that this wire cannot be shorted to the chassis at any point.

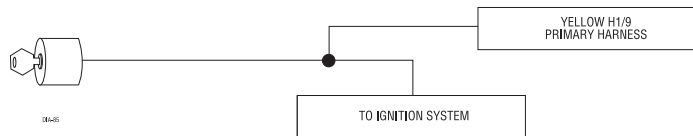

H1/10 BROWN (+) siren output: Connect this to the red wire of the 514T Revenger™ siren. Connect the black wire of the siren to (-) chassis ground, preferably at the same point you grounded the control module's H1/8 BLACK wire.

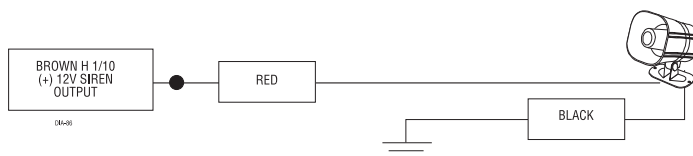

H1/11 RED (+)12V constant power input: Before connecting this wire, remove the supplied fuse. Connect to the battery positive terminal or the constant 12V supply to the ignition switch as described on Page 5.

NOTE: Always use a fuse within 12 inches of the point you obtain (+)12V. Do not use the 15A fuse in the harness for this purpose. This fuse protects the module itself.

H1/12 RED/WHITE channel 2, (-) output: When the system receives the code controlling channel, for longer than 1.5 seconds, the red/white will supply a (-) 200mA output as long as the transmission continues. This is often used to operate a trunk/hatch release or other relay-driven function.

IMPORTANT! Never use this wire to drive anything but a relay or a low-current input! The transistorized output can only supply 200 mA of current, connecting directly to a solenoid, motor, or other high-current device will cause it to fail.

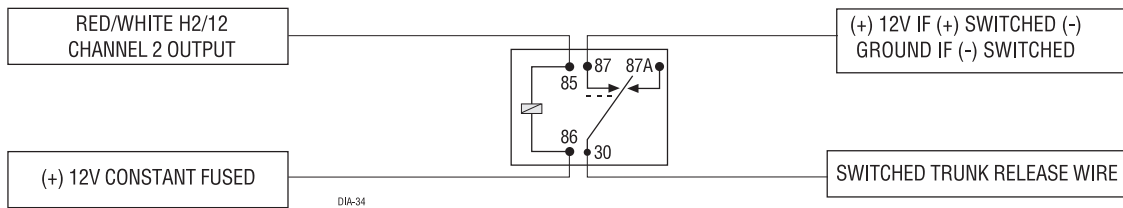

LED AND VALET®/ PROGRAM SWITCH

These plug into the module. The Status LED plugs into the small two-pin socket, while the Valet® /Program Switch should be plugged into the larger blue two-pin connector. The Status LED fits in a 9/32" hole.

Status LED

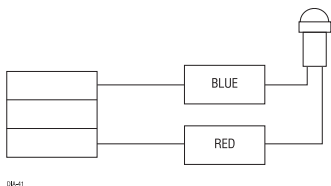

Valet®/Program Switch

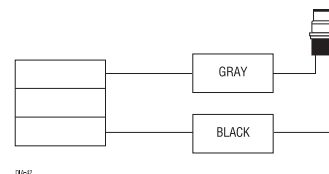

FOUR-PIN SHOCK SENSOR HARNESS

Green (-) Multiplex input: Inputs shorter than .8 seconds will trigger the Warn Away® response, while inputs longer than .8 seconds will trigger full alarm sequence and report zone four. If installing an optional DEI® dual stage sensor, connect to the green wire as shown below. The diagram below eliminates the need for diodes to isolate the sensors, as well as providing a separate zone for each sensor.

Diagram for adding optional DEI® dual stage sensor to GREEN wire (zone 4)

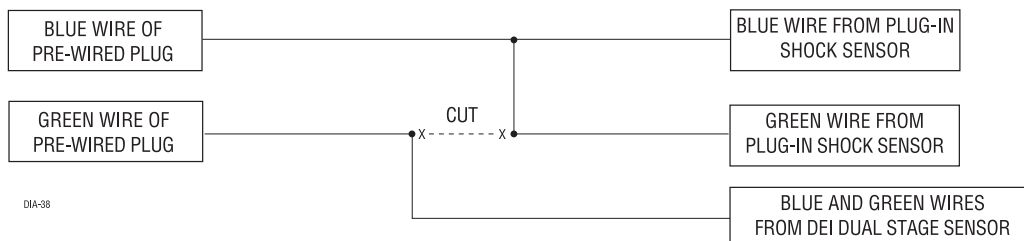

Blue (-) Multiplex input: Inputs shorter than .8 seconds will trigger the Warn Away® response, while inputs longer than .8 seconds will trigger full alarm sequence and report zone two.

Red, Black: Red is (+)12V constant, black is (-) ground. Do not use these for anything besides the plug in shock sensor.

BYPASSING SENSOR INPUTS

There are times when you need to temporarily bypass all sensor inputs to the unit, such as when remote starting the vehicle. Anytime an auxiliary channel output is used, all inputs are bypassed for 5 seconds. During the 5 second bypass period, ground can be supplied to the H1/6 BLUE wire without triggering the unit. When the 5 second bypass period ends, if the unit sees ground on the H1/6 BLUE wire, all trigger inputs except the door trigger input will remain bypassed until 5 seconds after ground is removed from the blue wire. This can be done using the status output of a 551T remote start unit as shown below:

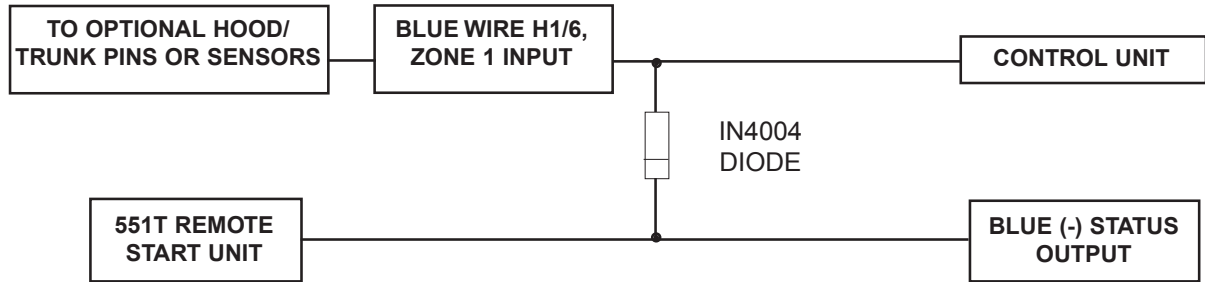

HARNESS 2, (+/-) DOOR LOCK OUTPUTS

H2/A	GREEN	(-) LOCK, (+) UNLOCK OUTPUT
H2/B	EMPTY	UNLESS USING 451M
H2/C	BLUE	(-) UNLOCK, (+) LOCK OUTPUT

This system can control two common power door lock types without any additional parts! With certain vehicles, or if an actuator is to be installed, either a 451M Door Lock Relay Satellite or two relays will be required.

IMPORTANT! If you mistake a Type C direct-wired system for a Type A positive-pulse system, the module will be damaged!

Type A - (+) 12V pulses from the switch to the factory relays

The system can control this type of system directly, with no additional parts. The switch will have three wires on it, and one will test (+)12V constantly. The others will alternately pulse (+)12V when the switch is pressed to the lock or unlock position.

If you cannot get to the switch, and you find a set of wires that pulse (+)12V alternately on lock and unlock, you must take care to ensure that it is not a Type C direct-wire system.

Here is a test: Cut the wire which pulses (+)12V on lock, and then operate the switch to unlock.

If all doors unlock, the vehicle uses type A system.

If you lose all door lock operation in both directions, you are operating the master switch in a Type C system.

If you lose all door lock operation of one or more, but not all motors stop operating, and other doors still work, you have cut a wire leading directly to one or more motors. You must instead find the actual wires leading to the switch.

Many domestically-made GM vehicles use Type A locks. However, many more GM vehicles are Type C than in previous years. The full-size pickups (1989-up), many of the S10 Blazers, the Corvette, '95 Cavalier/Sunfire 1993 - and newer, Camaro/Firebird all use Type C door locks, and cannot be controlled without a 451M! Almost all domestically-built Fords are Type C. Ford builds almost no Type A systems. Chrysler builds both Type A and Type C, so use care.

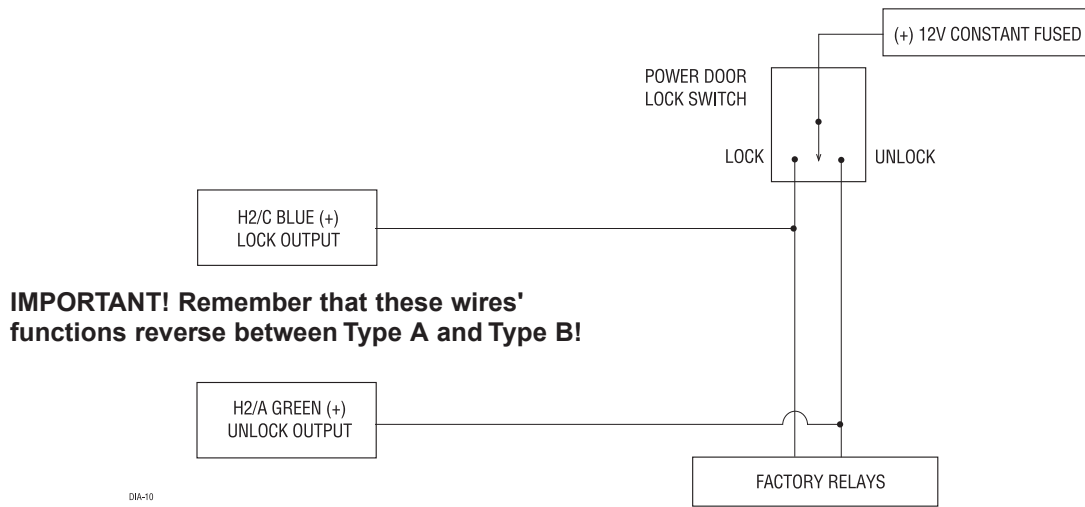

DIA-10

Type B - (-) pulses from the switch to the factory relays

This system is common in many Toyotas, Nissans, Hondas, and Saturns, as well as Fords with the keyless-entry system (some other Fords also use Type B).

The switch will have three wires on it, and one wire will test ground all the time. One wire will pulse (-) when the switch locks the doors, and the other wire will pulse (-) when the switch unlocks the doors. This type of system is difficult to mistake for any other type.

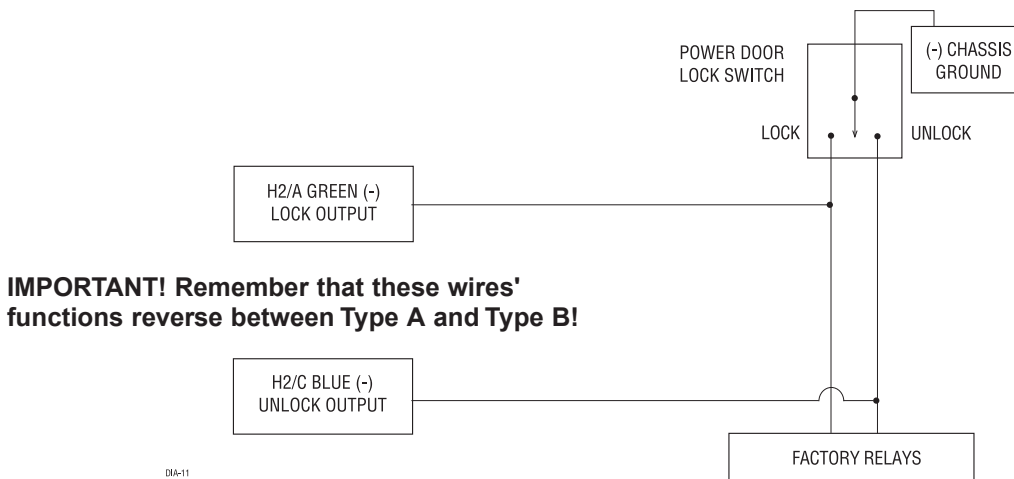

DIA-11

Type C - Reversing Polarity

Interfacing with a reversing polarity system requires either two relays or one 451M (not included). It is critical to identify the proper wires and locate the master switch to interface properly. Locate wires that show voltage on lock and unlock. Cut one of the suspect wires and check operation of the locks from both switches. If one switch loses operation in both directions and the other switch operates in one direction only, you have located one of the target wires. The switch that lost all operation is the master switch. If one switch works both directions and the other switch works only one direction, you have a Type A system. If both switches still operate, but one or more doors have stopped responding entirely, you have cut a motor lead. Reconnect it and continue to test for another wire. Once both wires have been located and the master switch identified, cut both wires and interface as shown below.

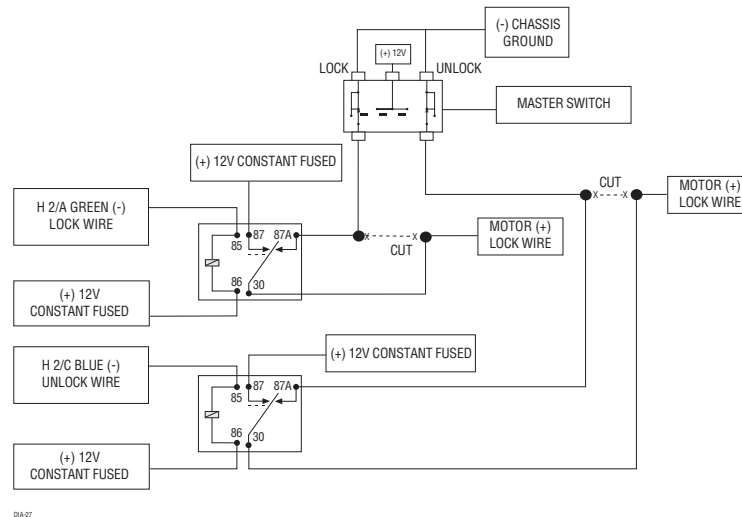

Important! If these are not connected properly, you will send (+) 12 Volts directly to (-) ground, possibly damaging the alarm or the factory switch.

Type D - Aftermarket Actuators

In order for this system to control one or more aftermarket actuators, a 451M or two relays (optional) are needed. Vehicles without factory power door locks require the installation of one actuator per door. This requires mounting the door lock actuator inside the door. Other vehicles may only require one actuator installed in the driver's door if all door locks are operated when the driver's lock is used. This type of installation is required to operate factory lock systems in Volvo (except 850), SAAB, and most Mazda, Isuzu and Subaru models.

The fuse used on 12 volt inputs should be 7.5A per motor installed in the vehicle.

IMPORTANT! Do not connect the outputs of the alarm directly to the actuator!

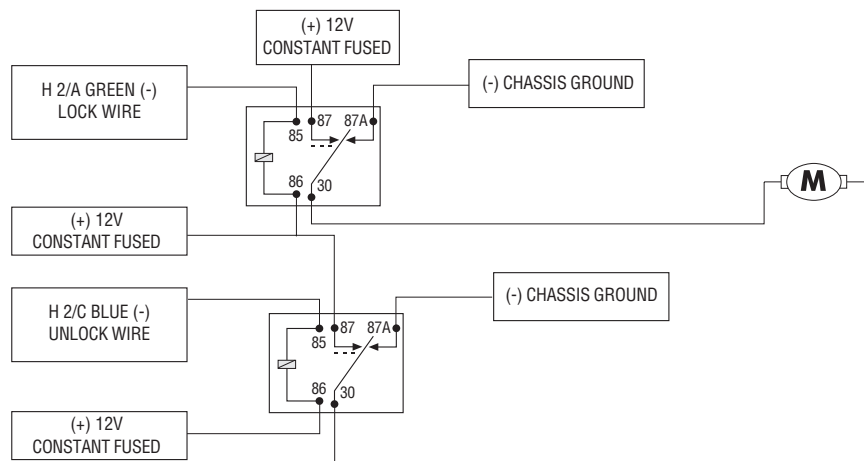

Type E - Mercedes-Benz and Audi (1985 & Newer)

Door locks are controlled by an electrically activated vacuum pump. Some Mercedes and Audis use a Type D system. Test by locking doors from the passenger key cylinder. If all the doors lock, the vehicle's door lock system can be controlled with just two relays (optional). The control wire can be found in either kick panel and will show (+)12V when doors are unlocked and (-) ground when doors are locked. To interface see diagram below. The system must be programmed for 3.5 second door lock pulses (see Operation-Settings Learn Routine™).

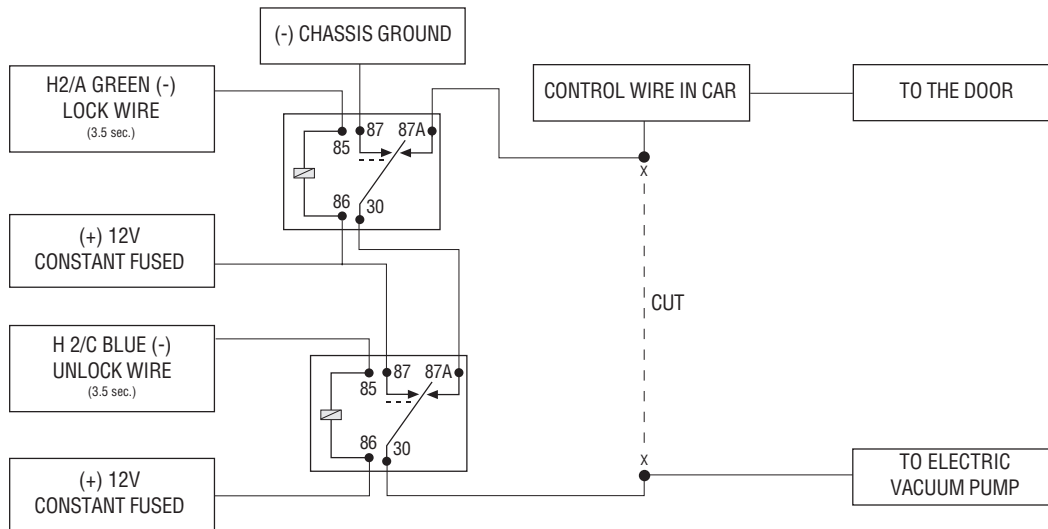

DIA-29

Type F - One-Wire System

This system usually requires a negative pulse to unlock, and cutting the wire to lock the door. In some vehicles, these are reversed. It is found in late-model Nissan Sentras, some Nissan 240SX, and Nissan 300ZX 1992-up. It is also found in some Mazda MPV's and some Mitsubishi's. One relay (optional) is used to interface to this type of system as follows:

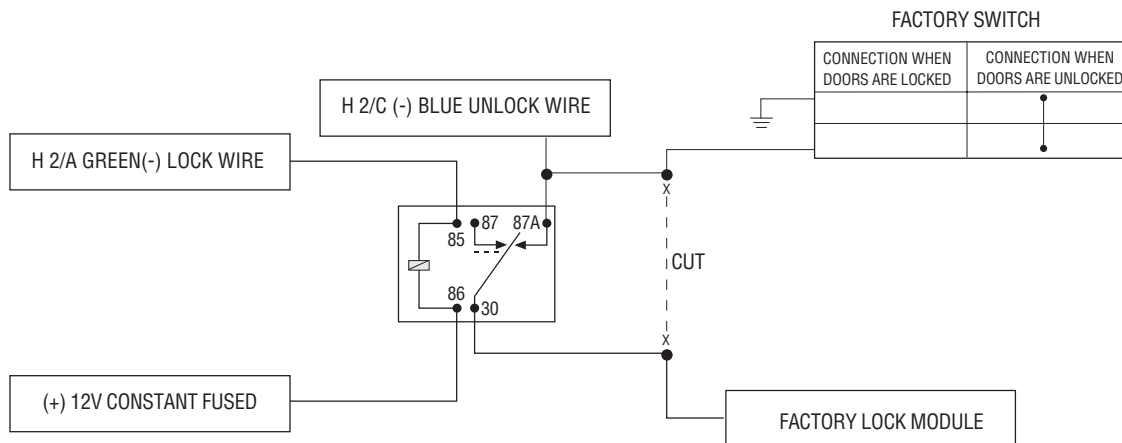

DIA-30

TRANSMITTER/RECEIVER LEARN ROUTINE™

In order to enter Learn Routine™, the jumper under the sliding door must be placed into learn position (see page 9). The Valet®/Program button, plugged into the blue port, is used for programming. There is a basic sequence to remember whenever programming this unit: Door, Key, Choose, Transmit and Release.

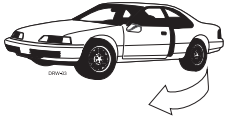

1. Door Open a door. Either the H1/5 green or the H1/7 violet door trigger wire must be connected for the control unit to “see” an open door.



2. Key Turn the ignition on to the run position. The H1/9 yellow switched ignition input must be connected.



3. Choose Within 15 seconds, press and release the momentary button to select the channel you wish to program:

Press and Release	To Program
One time	Arm/disarm/panic
Two times	Channel two output (Silent Mode™/Remote Valet®)
Three times	Channel three output

Once you have selected the step, press the button once more and hold it. The unit will chirp one, two or three times depending on the channel selected. Do not release the momentary button.



4. Transmit While holding the momentary button, press the button on the transmitter that you would like to control the selected receiver channel. One chirp will confirm that the code has been learned.



5. Release Once the code is learned, the Valet® button can be released.

You can step from one step to another by releasing the Valet® /Program button and tapping it to advance steps and then holding it. For instance: You have programmed channel one and you want to program channel two. Release the Valet® /Program button. Press it one time and release it to advance from step one to step two. Now, press and hold the button down and the unit will chirp twice. As before, do not release it.

If you want to program channel three after programming channel one, release the momentary button press it twice and release it to advance to step three. Then press it once more and hold it. The siren will chirp three times to confirm it is ready to receive the code from the transmitter.

Learn Routine™ will be exited if:

- Ignition is turned off.
- Door is closed.
- Program button is pressed too many times.
- More than 15 seconds elapses between steps.

One long chirp indicates that Learn Routine™ has been exited.

TWO-VEHICLE OPERATION WITH SINGLE TRANSMITTER

You can get two-vehicle operation with the transmitters that come with the system. However, you cannot use all the auxiliary channels of the system (or all the auxiliary channels of the other system), unless using 475T 4-button transmitter.

Here's what to do:

- 1) Using Learn Routine™, program button I into system # 1 as the arm/disarm button. Do this with all four remotes.
- 2) Do the same with system # 2, except program button II of all four remotes as the arm/disarm button.

If using DEI® 475T four-button remotes, all auxiliary channels are available on both vehicles. Before programming, make a list of all channels on each vehicle, and decide which button(s) should control which channel.

For example, if you wanted the top two buttons to control vehicle # 1 and the bottom two buttons to control vehicle # 2, here is how each system would be programmed:

Vehicle # 1: Button I = arm/disarm.

Button II = trunk release/Silent Mode™.

Button I+II = channel three.

Vehicle # 2: Button III = arm/disarm.

Button IV = trunk/release/Silent Mode™.

Button III+IV = channel three.

OPERATING-SETTINGS LEARN ROUTINE™

Many of the operating settings of this unit are programmable. They can be changed whenever necessary through a computer-based Learn Routine™. In order to access Learn Routine™, the jumper underneath the sliding door on the module must be in the learn position (see page 9). The Valet® /Program push-button switch, plugged into the blue port is used together with a programmed transmitter to change the settings. To program settings remember: Door, Key, Choose, Transmit and Release.

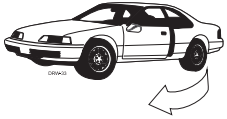

1. Door Open a door. Either the H1/5 green or the H1/7 violet door trigger wire must be connected for the control unit to “see” an open door.



2. Key Turn the ignition on and then back off. The H1/9 yellow switched ignition input must be connected.



3. Choose Within 15 seconds, press and release the Valet®/Program button the number of times corresponding to the number of the desired feature (see the chart below). The one chirp settings below are the factory default settings, except where indicated by bold text.

Feature Number	One-chirp setting	Two-chirp setting
1	Active arming	Passive arming
2	Arm/disarm chirps on	Arm/disarm chirps off
3	Ignition-controlled door locks	Standard door locks
4	Active locking only	Passive locking
5	Panic with ignition on	No panic with ignition on
6	0.8 second door lock pulses	3.5 second door lock pulses
7	Forced passive arming on	Forced passive arming off
8	Automatic engine disable on	Automatic engine disable off
9	VRS® enabled	VRS® disabled
10	Code Hopping™ on	Code Hopping™ off
11	Siren	Horn honk
12	Standard unlock pulse	Double unlock pulse

Once the button has been pressed and released the correct number of times press it once more and hold it. After a second, the siren will chirp to indicate what step you have accessed. For example, three chirps would indicate access to the ignition controlled door lock feature.

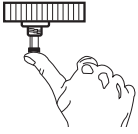

4. Transmit While holding the Valet® /Program button, use the arm/disarm button of the transmitter, to toggle between the one and two chirp settings. The one-chirp settings are the factory defaults.



5. Release The Valet® button can now be released.

For example, to program the arming mode from active to passive, press and release the Valet®/Program button once. Then press and hold it. The siren will chirp once, indicating that the setting can now be changed. While holding the Valet® /Program button, press the arm/disarm button on the transmitter. The siren will chirp twice to indicate that passive arming has been programmed. If this is the desired setting, release the Valet® /Program button. If this is not the desired setting, continue to hold the Valet® /Program button and press the arm/disarm button on the transmitter again. The siren will chirp once indicating that active arming has been programmed. Once the desired setting has been selected, release the Valet® /Program button.

You can advance from step to step by pressing and releasing the Valet® /Program button the number of times necessary to get from the step you just programmed to the step you wish to access. If you just programmed the arm/disarm chirps to off and you want to program passive locks, release the Valet® /Program button, press and release it twice to step from feature two to feature four. Then press it once more and hold it. The unit will chirp four times to confirm that you have accessed feature number four.

The Learn Routine™ will be exited if:

- The ignition is turned on.
- The door is closed.
- The Valet® button is pressed too many times.
- More than 15 seconds elapses between steps.

The siren will emit a long chirp when Learn Routine™ is exited.

FEATURE DESCRIPTIONS

1. **ACTIVE/PASSIVE ARMING:** When active arming is selected, the system will only arm when the transmitter is used. When set to passive, the system will arm automatically 30 seconds after the last door is closed. Passive arming is indicated by the rapid flashing of the LED when the last protected entry point is closed.
2. **ARM/DISARM CHIRPS ON/OFF:** This feature controls the chirps that confirm the arming and disarming of the system.
3. **IGNITION CONTROLLED DOOR LOCKS ON/OFF:** When turned on, the doors will lock three seconds after the ignition is turned on and unlock when the ignition is turned off. The doors will not lock if the ignition is turned on with the door open.
4. **ACTIVE/PASSIVE LOCKING:** If passive arming is selected in step one, then the system can be programmed to either lock the doors when passive arming occurs, or only lock the doors when the system is armed via the transmitter. Active locking means the system will not lock the doors when it passively arms. Passive locking means that the system will lock the doors when it passively arms.
5. **PANIC WITH IGNITION ON:** This step controls whether or not the panic mode is available with the ignition on. In some states, there are laws prohibiting a siren sounding in a moving vehicle. This feature makes the system compliant with these regulations.
6. **DOOR LOCK PULSE DURATION:** Some European vehicles, such as Mercedes-Benz and Audi, require longer lock and unlock pulses to operate the vacuum pump. Programming the system to provide 3.5 second pulses, will accommodate door lock interface in these vehicles. The default setting is .8 second door lock pulses. See "Mercedes-Benz and Audi - 1985 and Newer (Type E)" diagram on page 15.
7. **FORCED PASSIVE ARMING ON/OFF:** To use this feature, passive arming must be selected in step one. When turned on, forced passive arming will ensure that the system will passively arm, even if a zone is left open or invalid. Forced passive arming occurs one hour after the ignition is turned off.
8. **AUTOMATIC ENGINE DISABLE (AED) ON/OFF:** AED is a full time, passive starter disable that works independently of the security system. When turned on, the H1/1 orange, ground when armed output will go active 30 seconds after the ignition is turned off. The LED will flash at half its normal rate when the ignition is turned off to indicate that AED is on and will interrupt the starter in 30 seconds. AED does not occur in Valet® mode and can be bypassed using the emergency override procedure. The transmitter can be used to disarm AED, however, the system would have to be armed and then disarmed when using the transmitter.
9. **VEHICLE RECOVERY SYSTEM (VRS®) ENABLED/DISABLED:** This feature is used to tell the system whether or not the VRS® button has been installed. As shipped, the VRS® is disabled. If installing the VRS® button, you will need to enable the VRS®.
10. **CODE HOPPING™ ON/OFF:** The system uses a mathematical formula to change its code each time the transmitter and receiver communicate. This makes the group of bits or "word" from the transmitter very long. The longer the word is, the easier it is to block its transmission to the unit. Disabling the Code Hopping™ feature lets the receiver ignore the Code Hopping™ part of the transmitter word. As a result, the unit may have better range with Code Hopping™ off.
11. **SIREN/HORN HONK:** The system can be programmed to output pulses instead of a continuous output when the system is triggered. This is useful to honk the factory horn in applications where a siren is undesirable. Remember that the unit is only capable of supplying 1 amp of current. A relay will be required to interface with most factory horn systems.
12. **DOUBLE PULSE UNLOCK ON/OFF:** Some vehicles require two pulses on a single wire to unlock the doors. When the double pulse unlock feature is turned on, the BLUE H2/C wire will supply two negative pulses instead of a single pulse. At the same time, the GREEN H2/A wire will supply two positive pulses instead of a single pulse. This makes it possible to directly interface with double pulse vehicles without any extra parts.

FINAL TESTING

Nuisance Prevention Circuitry™

NPC™ requires that you change the way you test the system as NPC™ will bypass an input zone for 60 minutes.

If the system “sees” the same zone trigger three times **AND** the triggers are spaced less than an hour apart, the system will bypass that input zone for 60 minutes.

If that zone does not attempt to trigger the system during the 60-minute bypass period, the zone’s monitoring will begin again at the end of the hour. **NEW! If it does attempt to trigger while bypassed, the 60-minute bypass starts over again.**

Disarming and rearming the system does not reset NPC™. The only way to reset NPC™ is for the 60 minutes to pass, without a trigger, or for the ignition to be turned on. This allows the system to be repeatedly triggered, disarmed and rearmed, and still allow NPC™ to bypass a faulty zone. When disarming the system, 5 chirps indicate NPC is activated. The LED will report the zone that has been bypassed (see diagnostics).

VALET® MODE

To enter or exit Valet® Mode with the Valet®/program switch:



Turn the ignition key on then off.

At anytime during the next 10 seconds, press and release the Valet® switch.



Now the Status LED will light up constantly if you have entered Valet® Mode, and go out if you have exited.

To enter or exit Valet® Mode with a transmitter:

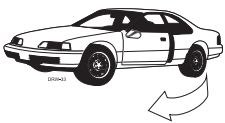

Open any door.

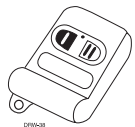

Press button 1 (or the arm/disarm button).



Press button 2 (or the channel 2 button).



Press button 1 again.

You have now entered or exited Valet® Mode (verify by checking your Status LED).

TABLE OF ZONES

When using the Diagnostic functions, use the Table of Zones to see what input has triggered the system. It is also helpful in deciding what input to use when connecting optional sensors and switches.

Zone #	Trigger type	Input description
One	Instant	H1/6 BLUE wire. Connect to optional hood/trunk pins.
Two	Multiplex	Blue wire of plug-in shock sensor. Inputs shorter than .8 seconds will trigger a Warn Away® response, while inputs longer than .8 seconds will instantly trigger full alarm sequence.
Three	Two-stage, progresses from warning to full alarm	Door switch circuit. H1/5 GREEN or H1/7 VIOLET.
Four	Multiplex	Green wire of plug-in shock sensor. Inputs shorter than .8 seconds will trigger a Warn Away® response, while inputs longer than .8 seconds will instantly trigger full alarm sequence.
Five	Two-stage (similar to doors)	Ignition. H1/9 yellow. <small>The Warn Away® response does not report on the LED.</small>

VEHICLE RECOVERY SYSTEM® INSTALLATION

To install the optional VRS® feature, the 8618 starter kill relay must be installed. Mount the button in a well-hidden location and plug it into the red VRS® port on the control unit. Make sure it cannot be pressed accidentally. The switch must be placed where it can be reached from the driver's seat. Make sure that the customer is aware of the location of the button and is familiar with the VRS® triggered sequence. This will ensure that the customer does not become stranded by the VRS®.

IMPORTANT: If the VRS® button is being installed, you must enable the VRS®. Refer to Operation Settings Learn Routine™ section on page 18.

A few minutes are required to test the VRS®. To test:



Open the Owner's Guide to Vehicle Recovery System® section. The triggered sequence is described in detail.

Press and release the VRS® push-button switch, with a door open.



Turn on the ignition and close all the doors.

Wait 15 seconds. The Status LED will begin flashing. This will be followed by chirps and flashing lights, then by constant siren, in timed progressions described in the Owner's Guide.



The starter kill will be turned on via the orange wire: A) if the ignition is turned off after the chirps have stopped; or B) as soon as the siren progresses to constant output.

IMPORTANT!: You must make sure that all users of the vehicle know how to disarm the VRS®. Remember that the remote does not affect the VRS®, so make sure the user can distinguish the standard triggered response from that of the VRS®.

TROUBLESHOOTING

Starter kill doesn't work:

Is the correct starter wire being interrupted? If the car starts when the starter kill relay is completely disconnected, the wrong starter wire has been cut and interrupted.

Starter kill doesn't work only in the VRS® mode:

H1/9 Yellow wire is not connected to true ignition. It is connected to an accessory circuit. See page 10.

Shock sensor doesn't trigger the alarm:

Has the NPC™ system been triggered? If so, you will hear 5 chirps when disarming. To check this, turn the ignition key on and off to clear the NPC™'s memory, and then re-test the shock sensor. For a detailed description of NPC™, see Final Testing page 21.

Door input does not immediately trigger full alarm. Instead, first I hear chirps for 3 seconds:

That's how the progressive two-stage door input works! This is a feature of this system. This is an instant trigger, remember, since even if the door is instantly re-closed, the progression from chirps to constant siren will continue.

Closing the door triggers the system, but opening the door does not:

Have you correctly identified the type of door switch system? This happens often when the wrong door input has been used. See page 10.

System will not passively arm until it is remotely armed and then disarmed:

Are the door inputs connected? Is the H1/6 blue wire connected to the door trigger wire in the vehicle? Either the H1/5 green or the H1/7 violet should be used instead. See page 10.

Door input does not respond with the progressive trigger, but with immediate full alarm:

Does the Status LED indicate that the trigger was caused by the shock sensor? (See Diagnostics). The shock sensor, if set to extreme sensitivity, may be detecting the door unlatching before the door switch sends its signal. Reducing the sensitivity can solve this problem.

The Valet®/Program switch doesn't work.

Is it plugged into the correct socket? See page 11.

VRS® feature doesn't work.

Did you install the switch in the right socket? Did you enable the feature? Did you read the Owner's Guide for operation of this VRS® feature? (It differs from the outboard 540T VRS® system). See page 22. Are you arming the VRS® with the door closed?

Status LED doesn't work.

You've probably guessed already, but here goes: is it plugged in? See page 11. Is the LED plugged into the correct socket?

Door locks operate backwards.

This unit has easily-reversed lock/unlock outputs. Recheck page 12 to see if you have reversed these.