

TYP-A: positiv gesteuerte ZV

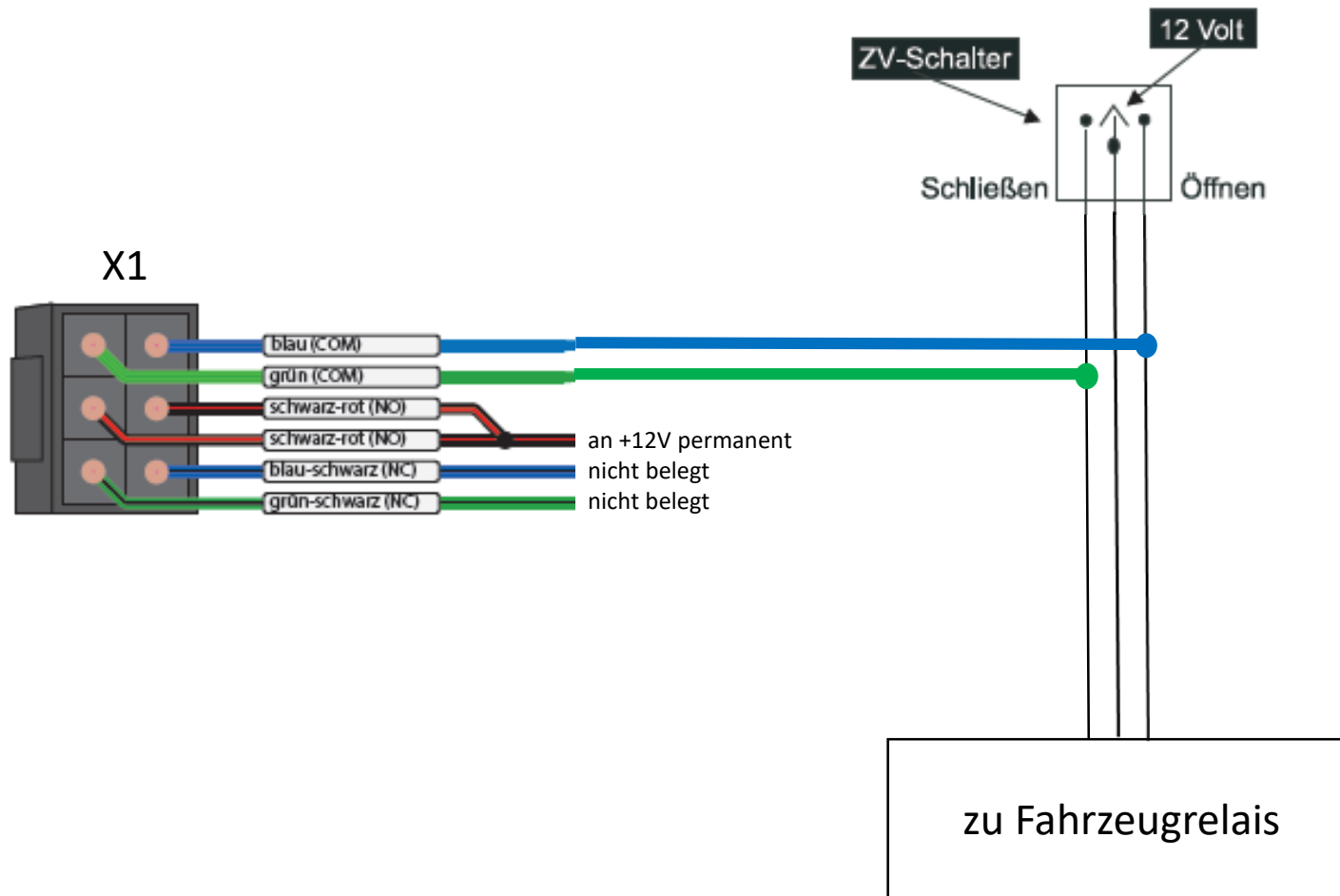

TYP-B: negativ gesteuerte ZV

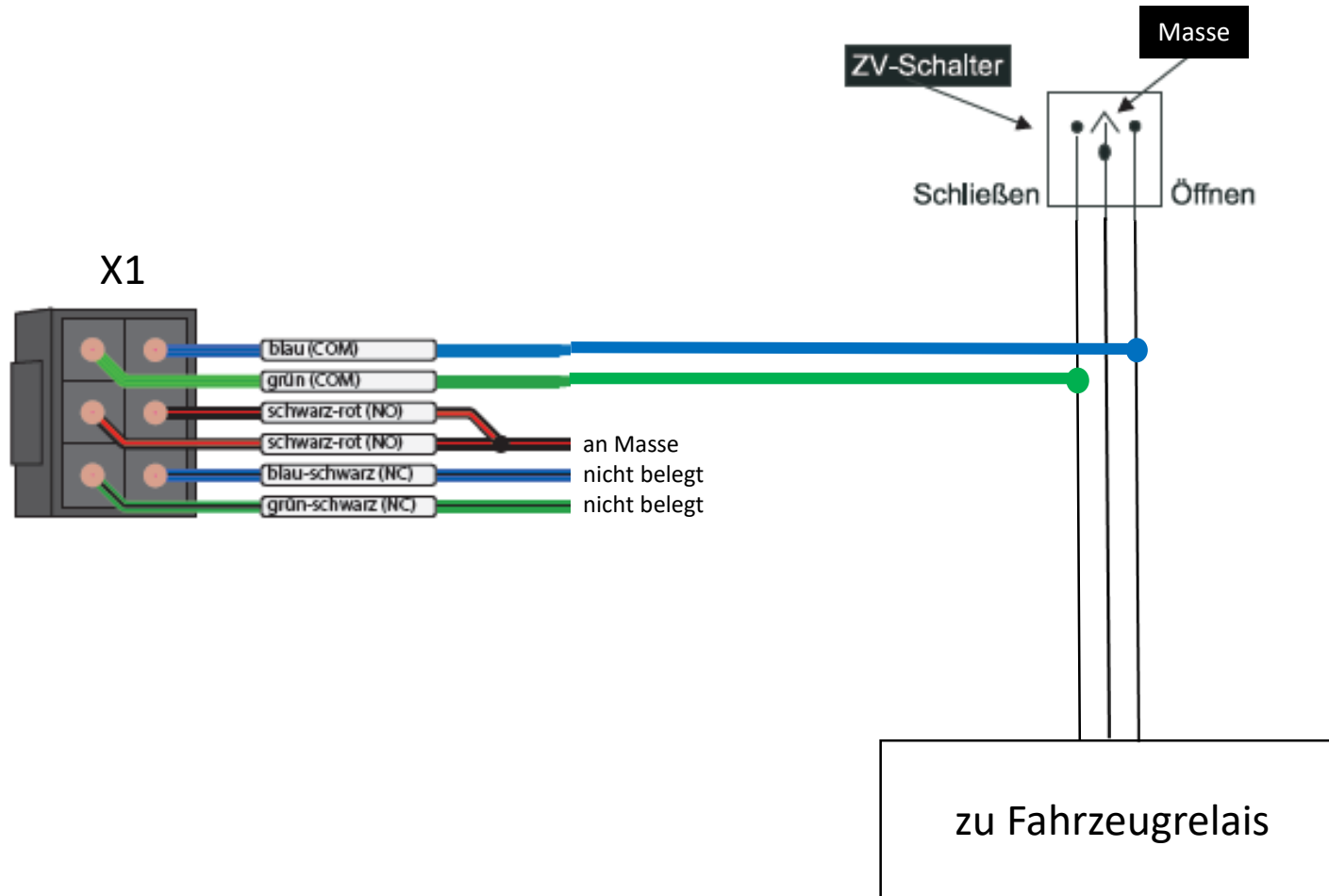

TYP-C: direktverkabelte, Polarität wechselnde ZV

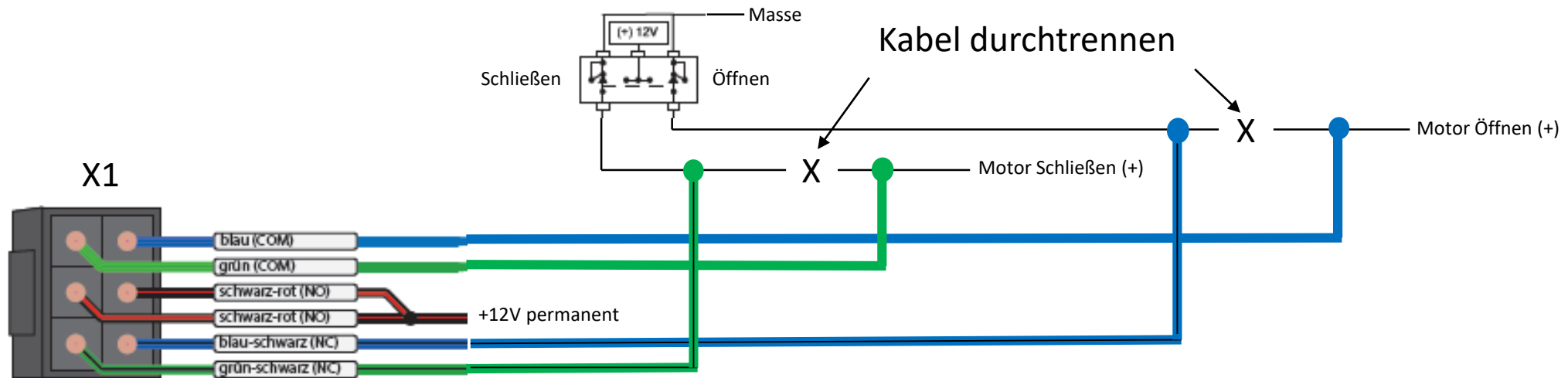

TYP-D: nachträglich installierter Stellmotor

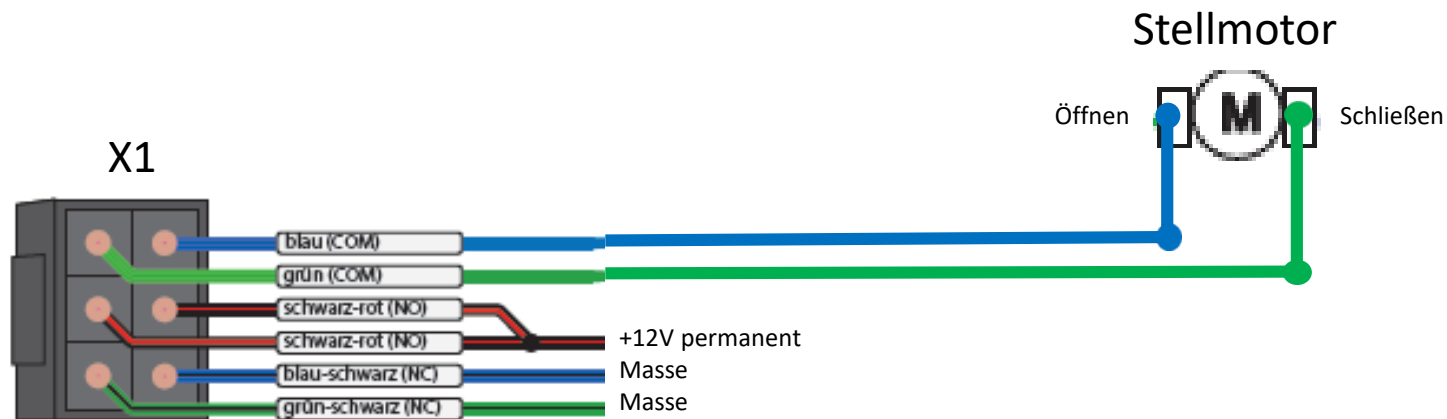

TYP-E: ZV über Vakuumpumpe

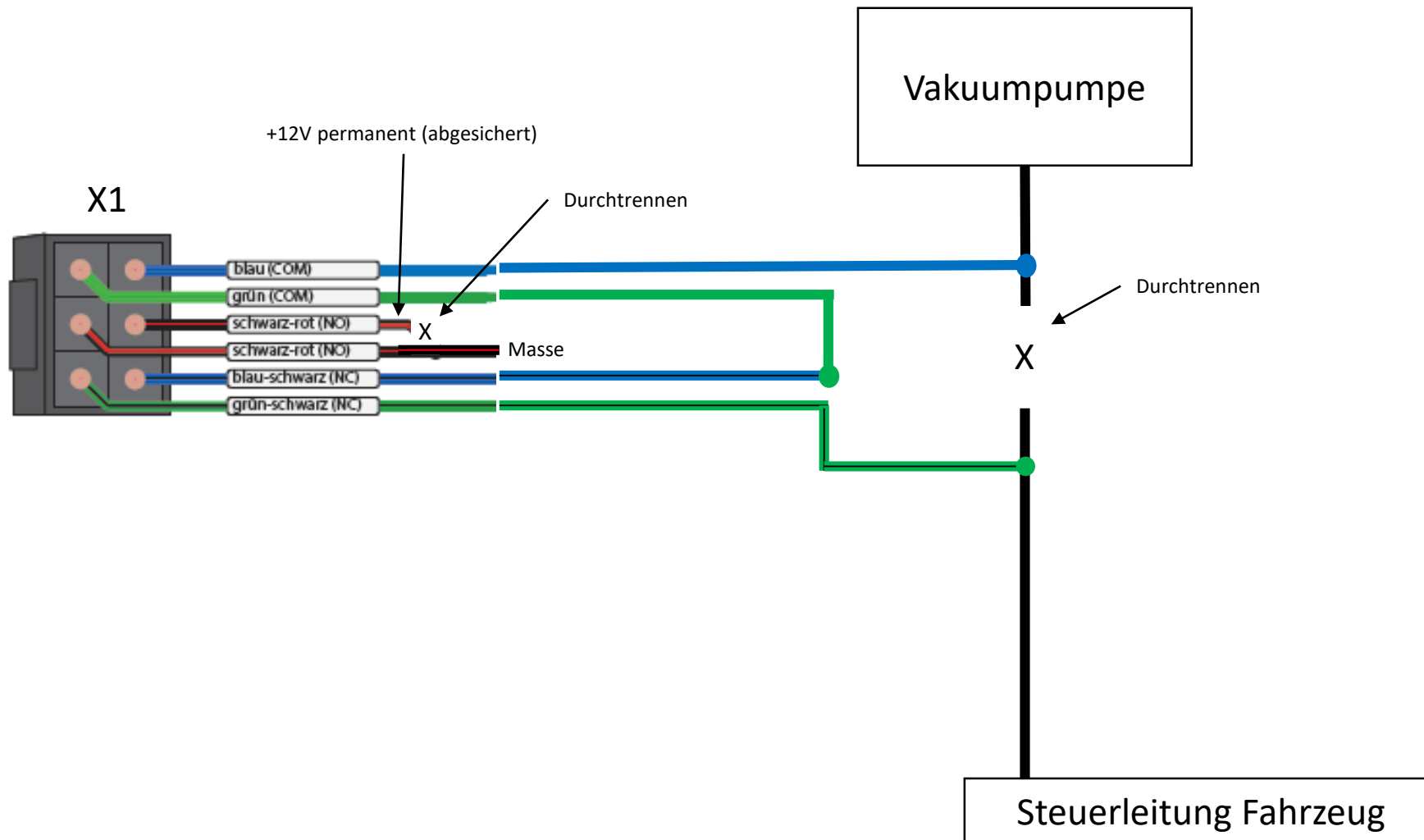

TYP-F: 1 Kabelsystem Trennen zum Schließen und Masse zum Öffnen

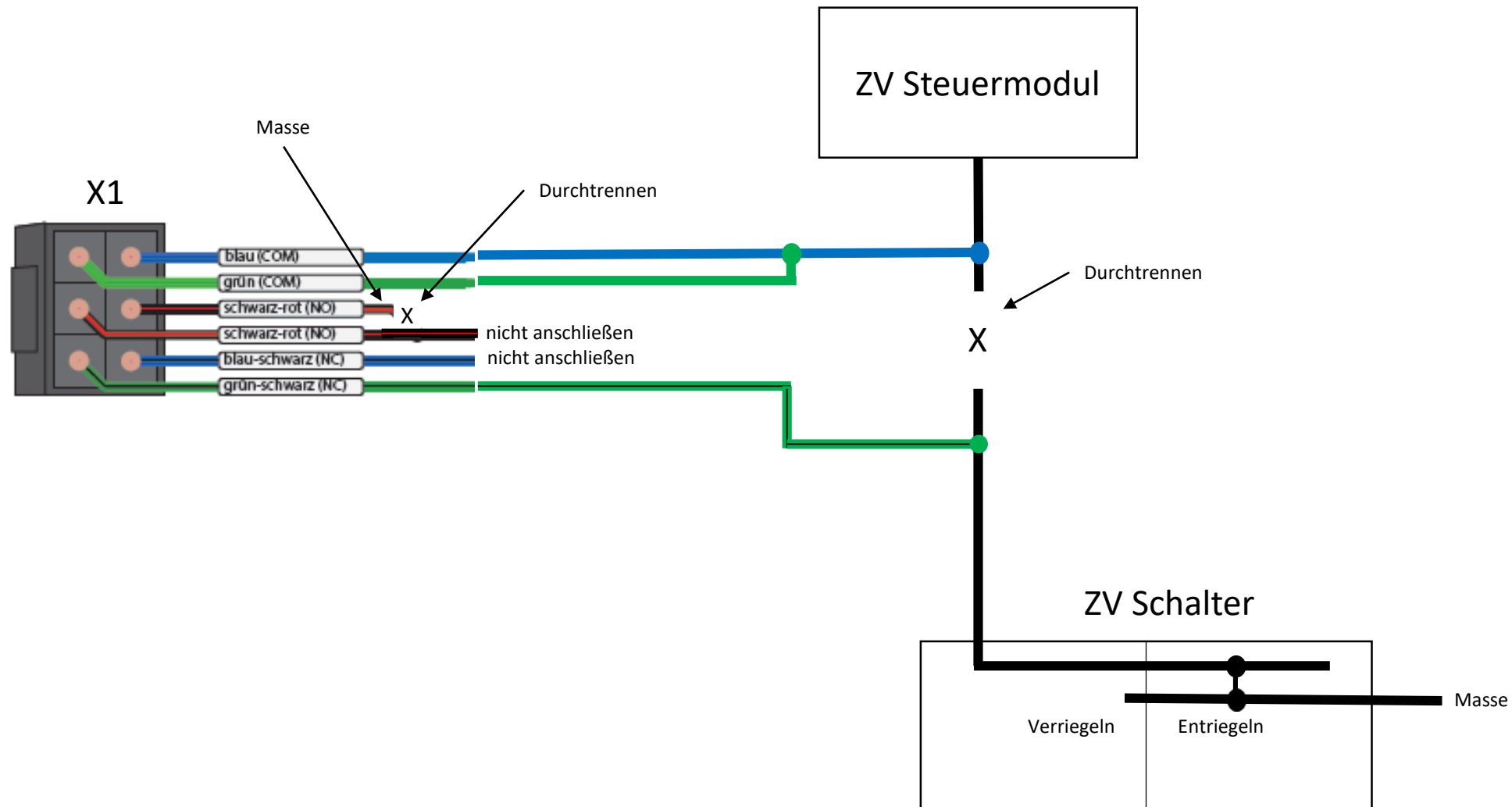

TYP-G: positiv Multiplex gesteuerte ZV

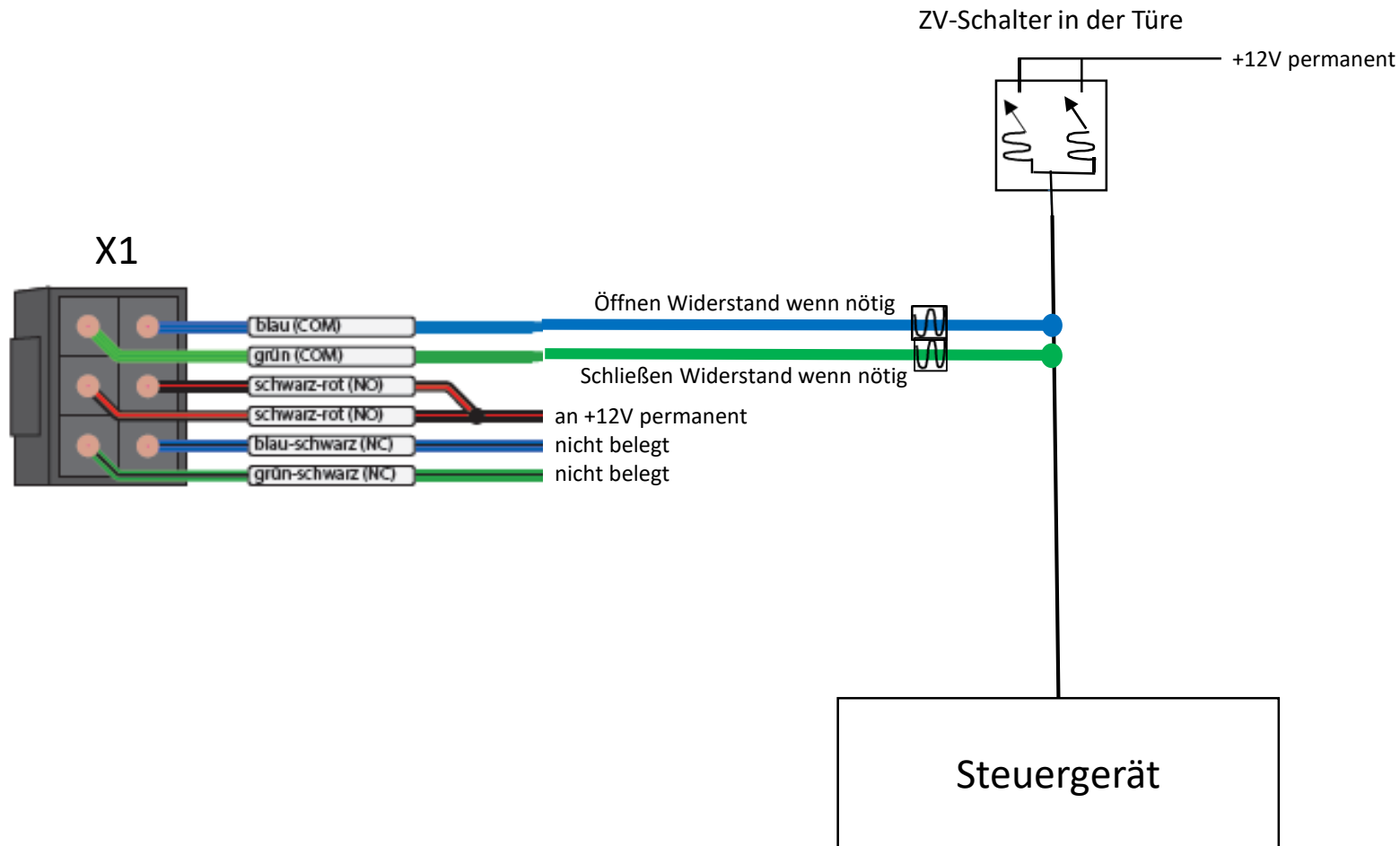

TYP-H: negativ Multiplex gesteuerte ZV

